

# Series

# 4000

# 5000

# 6000



**Polyvend<sup>®</sup>**  
Service Manual **Ltd.**

# TABLE OF CONTENTS

	PAGE
GENERAL INFORMATION.....	1
INSTALLATION.....	2
PRODUCT LOADING.....	4
SPECIAL PRODUCT LOADING.....	6
GUM AND MINT TRAY LOADING.....	8
CAN DISPENSER LOADING.....	9
PRIMARY CABINET COMPONENT INFORMATION.....	10
ELECTRICAL SERVICE SECTION.....	14
MODES OF OPERATION.....	14
DIAGNOSTIC ERROR CODES.....	16
BASIC KEY FUNCTIONS.....	16
DETAILED CONTROL BOARD OPERATIONS.....	17
SERVICE SECTION.....	22
CLEANING INSTRUCTIONS.....	23
WEDGE MODULE CHAIN REPLACEMENT.....	24
WEDGE ASSEMBLY REPAIR.....	30
TROUBLE SHOOTING.....	31
PARTS LISTS.....	35
COMPLETE ASSEMBLY (CABINET).....	36-38
CHILLER ASSEMBLY.....	39
DOOR STOP ASSEMBLY.....	40-41
SERVICE DOOR ASSEMBLY.....	42-44
HELIX ASSEMBLY.....	45
CANDY TRAY ASSEMBLY.....	46-47
PASTRY TRAY ASSEMBLY.....	48-49
CHAIN SEGMENT ASSEMBLY.....	50
RACK MODULE END ASSEMBLY.....	51
RACK MODULE ASSEMBLY.....	52-53
MODULE ARM MOTOR ASSEMBLY.....	54
SLIDING DRAWER WIRING ASSEMBLY.....	55
SLIDING DRAWER ASSEMBLY.....	56-57
WIRING DIAGRAM (CABINET).....	58-59
POWER BOX ASSEMBLY (MID-SIZE).....	60-61
POWER BOX ASSEMBLY (FULL SIZE).....	62-63
GUM AND MINT ASSEMBLY.....	64-65
CAN DISPENSER ASSEMBLY.....	66-67
ELECTRICAL SCHEMATIC DIAGRAM.....	69



**POLYVEND LTD.  
4000 5000 AND 6000 SERIES  
GLASS FRONT SERVICE MANUAL**

**GENERAL**

The Polyvend Automatic Merchandiser has independent dispensing units, with each dispenser activated by letter and number push buttons. The dispensing assemblies are installed with either plug-in, twist and lock helix or a wedge dispenser from the front of the machine. This design provides easy access to displaying units on location. The helix dispensing units are supplied with helices of various pitches to accommodate a range of products.

**SPECIFICATIONS**

Height (Full Size).....1800mm  
(Mid-size).....1800mm

Note: 4000M series machine does not come with legs and is 1676mm high. With optional legs, height is 1800mm.

Width (Full Size).....940mm  
(Mid-size).....800mm

Depth (Full Size).....724mm  
(Mid-size).....724mm

Shipping Weight (Full Size).....Approx. 273kg  
(Mid-size).....Approx. 236kg

**ELECTRICAL**

PRIMARY VOLTAGE.....EUROPE EXCEPT ENGLAND 220VAC 50 CYCLE 2 AMP.  
ENGLAND 240VAC 50 CYCLE 2 AMP.

SECONDARY VOLTAGE.....10.8/24 VAC

MAX. CURRENT.....3 AMP.

VOLTAGE TO CHANGER.....24 VAC



## INSTALLATION

- \* Remove shipping material from around the machine by cutting the shrink wrap at the top; then cut downward, keeping the knife over a cardboard corner post.
- \* Inspect for damage resulting from improper handling and if evident, file claim immediately with the carrier.
- \* Place machine into position and adjust leveling legs so machine is level and all legs are firmly on the floor.
- \* Remove keys from product dispensing compartment (in small manila envelope) and unlock the service door to remove the shipping cardboard.
- \* Check the operation of the service door and locking mechanism. They should operate smoothly and latch at all three locking plates.
- \* Place the price stickers on the front of the helix trays or on the end of the wedge delivery arms.
- \* Save the extra fuses, etc. found in the envelope as spare parts.
- \* Check to see that the power terminal on the transformer is attached to the proper terminal so it matches the local power supply voltage (220VAC or 240VAC). Note: This transformer is located in the bottom of the vending machine, in the right rear corner, inside the power box. See section on Hi-voltage power supply.
- \* **CAUTION: DISCONNECT POWER TO THE VENDING MACHINE BEFORE REMOVING THE CONTROL BOARD OR COIN CHANGER OR WORKING ON ANY ELECTRICAL COMPONENT IN THE MACHINE.**  
Failure to remove power to the machine could result in electrical damage to the vending machine.
- \* Install the coin changer equipment in the slide out drawer. Remember; the power to the slide out drawer is turned off when you pull out the drawer. To energize the drawer assembly, pull the plunger out, on interlock switch (See figure 10 pg. 10). Set the desired price for each item in accordance with the coin mechanism instruction sheet and the instructions provided in the "Electrical Service" portion of this manual. Note: Instructions for setting the prices of the control board are also provided on an instruction sheet above the control board in the slide out drawer assembly.
- \* Plug the machine into the power source.
- \* Load the coin changer with the proper denomination of coins.



- \* Check the operation of the vending machine with coins to verify that the changer is set for the correct denomination and that the proper selection operates with the selection made on the selector key pad.
- \* Ensure that all helix dispensers run in their channels and stop at the proper location for product dispensing.
- \* Test each one of the wedge chain assemblies to insure that they operate smoothly.
- \* Load the machine with product. (See Product Loading Section)
- \* Check that the helix trays latch in position and that the wedge dispensing arms are latched in place.
- \* Close and lock the service door.

**CAUTION: DISCONNECT POWER TO THE VENDING MACHINE BEFORE REMOVING THE CONTROL BOARD OR COIN CHANGER OR WORKING ON ANY ELECTRICAL COMPONENTS IN THE MACHINE.**



## PRODUCT LOADING

There are four different types of dispensers used in the 4000, 5000 and 6000 series machines.

They are:

- (1) Wedge type, primarily for bagged product.
- (2) Helix type, for bagged or boxed items.
- (3) Gum and Mint Dispenser (Slideout drawer style).
- (4) Can dispenser for dispensing can drinks, etc..

### WEDGE DISPENSER PRODUCT LOADING

1. To load, release the latch on each dispenser as shown in Figure 1 and pull the inside portion of the arm out until it comes to the stop.

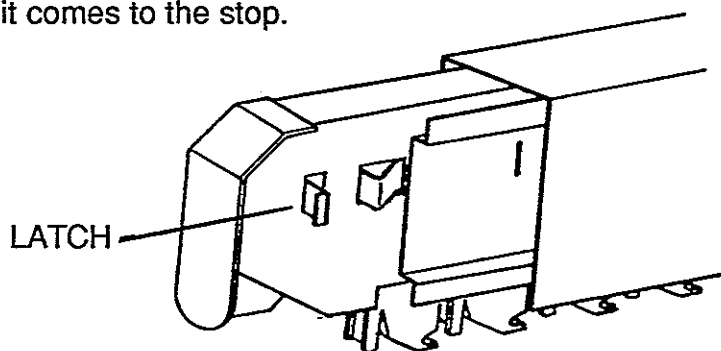

FIGURE 1

2. Each bag is inserted into a wedge assembly as shown in Figure 2. This can be done many ways; however, there is a best way which consists of inserting the bag into the wedge at an angle and sliding the bag up until centered in the wedge. **DO NOT ATTEMPT TO LOAD LAST POSITION ON EACH CHAIN.** Release product by pressing the white lever up behind the bag on the wedge assembly (See figure 2 below).

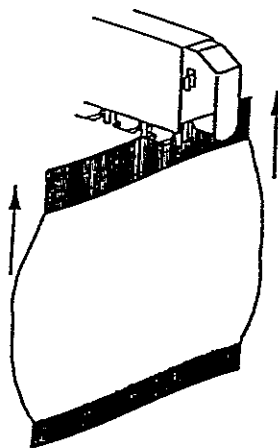

FIGURE 2

**CAUTION: DO NOT ATTEMPT TO PULL PRODUCT FROM THE BAG DISPENSER AT ANY TIME. SUCH ACTION WILL EITHER JAM THE MECHANISM OR PULL THE WEDGE ASSEMBLIES APART.**



## HELIX TRAY PRODUCT LOADING

There are several helix pitches. To insure proper operation and maximum capacity, the product size should closely match the opening between the windings of the helix. The product should fit between the windings of the helix so as not to be tight, but should fill most of the opening.

The helix sizes available are listed below

Candy Helix

14 count  
12 count  
10 count

Product Thickness

25.4mm thin candy bar  
31.75mm medium candy bar  
38.1mm large candy bar

Snack/Pastry

14 count  
10 count  
  
8 count

Product Thickness

25.4mm large cookie  
38.1mm medium chip bag or pastry  
47.6mm chip or pastry

## HELIX DISPENSER LOADING

To load a tray, release the white plastic stop on the bottom right of the tray. Pulling the tray front up and out, pull the tray out until it comes to the tray stop, then let it tilt down into the loading position.

At this point, check that each helix is in its proper position. See figure 3 below, which shows the proper position of the helix.

Starting at the front of the tray, insert a product between each winding of the helix so that the name of the product is displayed forward. Be sure to place the product all the way to the bottom of the tray and tilt free end at the top backwards. Fill from front to back and be sure not to miss any positions. Note: ALL PRODUCTS SHOULD RIDE ON SHELF AND NOT ON HELIX WIRE. After filling the tray, lift the front of the tray and push it back until the latch is engaged. Check that latch is fully engaged by pulling forward on the tray and ensuring that the tray does not advance beyond the latch.

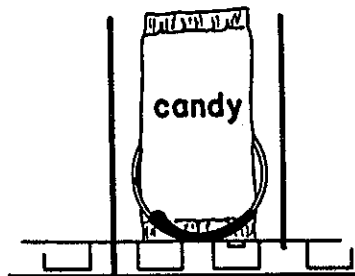

*Candy Helix In Detent Position*

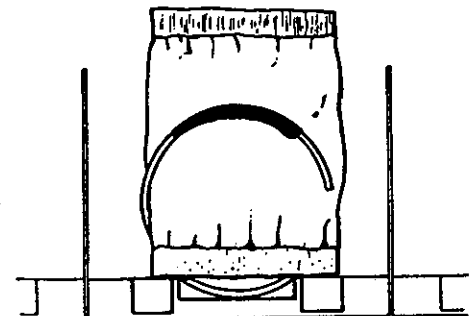

*Chip (Large) Helix In Detent Position*



## SPECIAL PRODUCT LOADING

### NARROW PRODUCT LOADING

In order to keep narrow products positioned properly, use of one of the spacer rails may be required. For additional rails order part no. 18244-02.

To install the spacer rail, press on to the tray divider as shown in Figure 4.

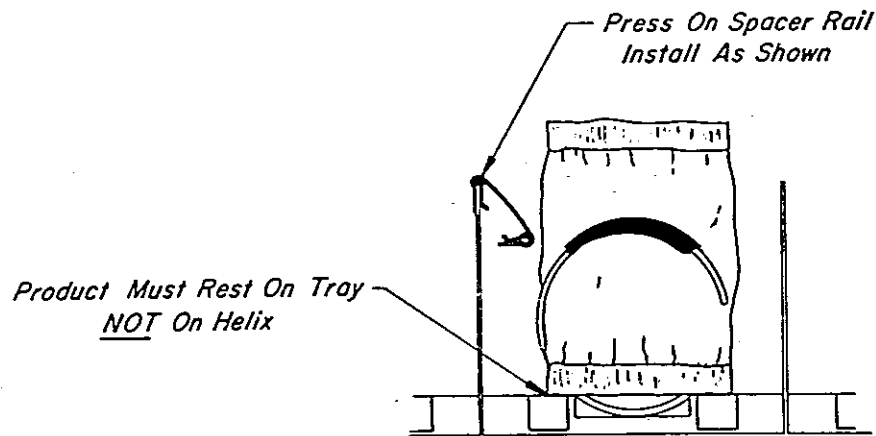

FIGURE 4

### SPLIT HELIX DISPENSER (OPTIONAL)

There is an optional split helix available that is installed in an existing candy helix to double the number of items in that selection. A special motor is used that turns only 180 degrees (Standard motor turns 360 degrees). The split helix is loaded with one product in each helix space on each side of the divider bar, See Figure 5.

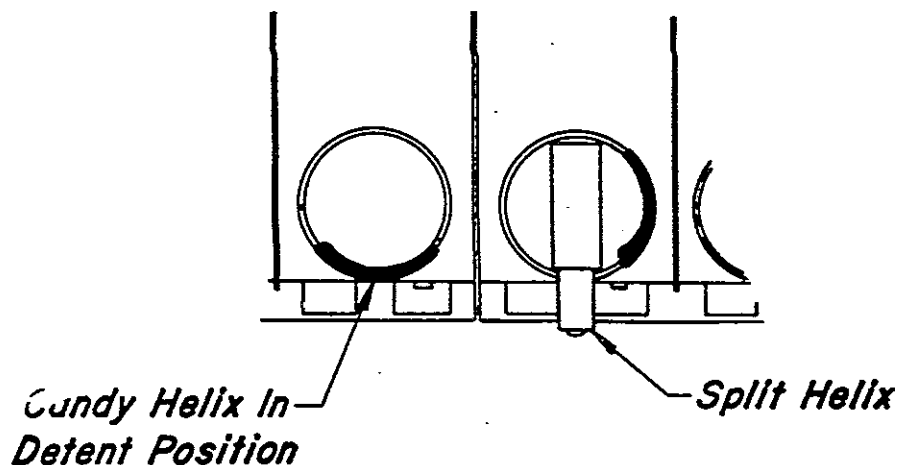

FIGURE 5





## HELIX DISPENSER REMOVAL

An individual helix can be removed for cleaning, repair or replacement with a different pitch while the tray is either in or out of the machine. Grasp the helix and twist it 10 to 15 degrees counter clockwise. Then pull forward and remove the helix from the tray. See figure 6 below.

To replace the helix, align the tabs on the helix hub with the slots in the white colored tray coupling. Push the helix into position and twist 10 to 15 degrees clockwise. Check to verify that the helix end is in the proper position and pull to insure proper connection.

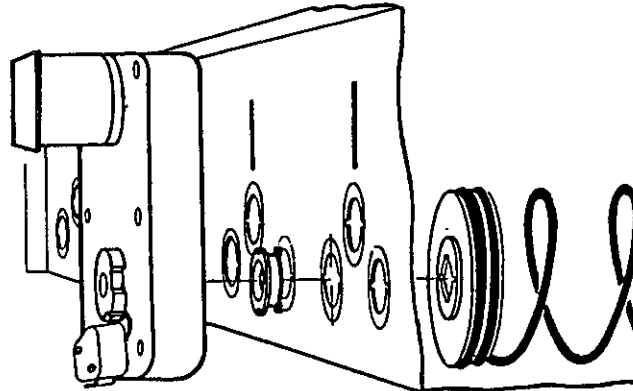

FIGURE 6

## FLAT OR SEMI-FLAT BOTTOM PRODUCT LOADING INSTRUCTIONS

Note: Instructions apply to candy tray only.

Certain candies and cigarettes have a flat or semi-flat bottom which is thick and wide. Polyvend has designed into our helix the flexibility to be 100% sure of the vending of this type of product. By moving the position of the helix and thus the helix kicker 90 degrees, the best dispensing for boxed products is ensured. You simply unlock the helix by twisting counter clockwise 10 to 15 degrees. Turn the helix counter clockwise 95 to 100 degrees then engage and twist clockwise to lock into place. The helix should be in the position as shown below in figure 7.

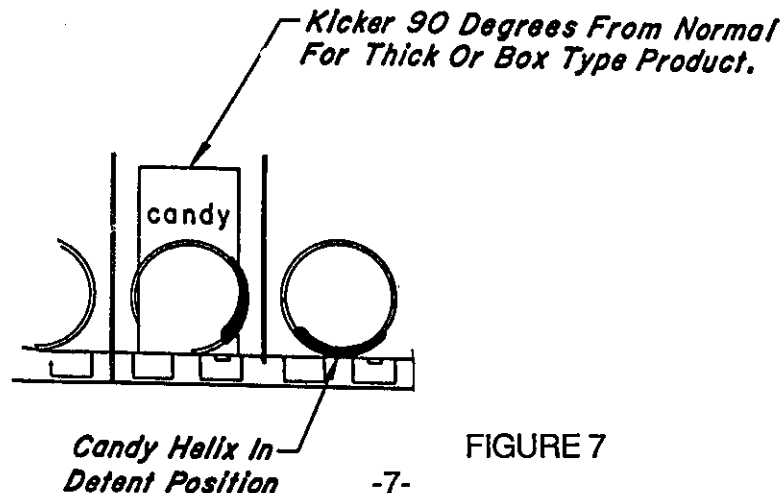

FIGURE 7



## GUM AND MINT TRAY LOADING (OPTIONAL) SLIDE OUT DRAWER STYLE

The three or four select gum and mint dispenser is available in kit form or can be factory installed. The three select gum and mint is installed in the 4000M, 5000M and 6000M. The four select gum and mint is installed in 4000, 5000 and 6000 series. Each module will hold up to 20 packs of gum or roll candy up to 139.7mm in length.

All machines are prewired from the factory so you can plug in the gum and mint kit if you decide to add the kit at a later date. The plug and harness are located in the bottom storage area above the high voltage electrical box.

### LOADING INSTRUCTIONS

Release the tray by pulling the two metal latches located on each side and sliding the tray forward. To load, push the cover toward the rear of the machine. See figure 8.

Load the product into the selection, with the product laying on its side. The selection may be loaded up to the pusher (SOLD OUT indicator). Load each selection with the desired number of product.

Each selection has a clear hinged product ejector which may require adjustment for each type of product. To adjust this ejector, loosen the wing nut and slide the assembly until the hinge knuckles are located entirely behind the first product and directly above the second product. Tighten the wing nut securely.

**IMPORTANT:** Before sliding the tray back into the machine, pull the cover forward over the product and under the retaining clips. Verify that both latches are engaged after the tray is pushed into dispensing position.

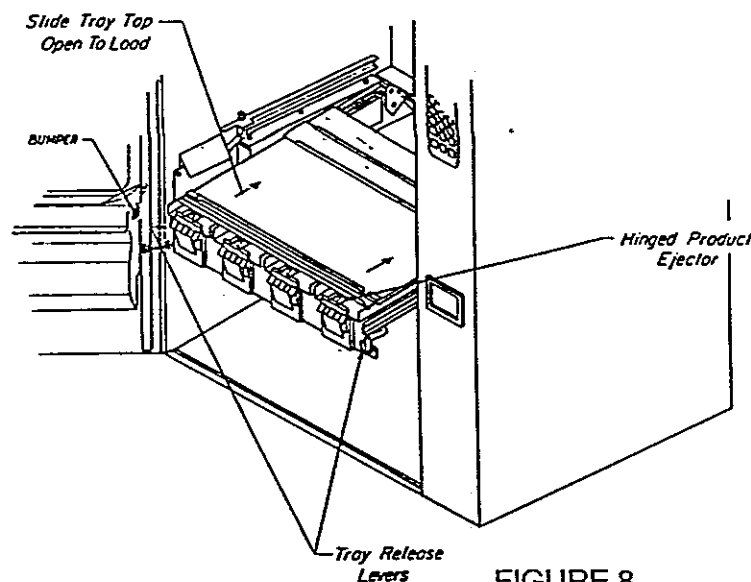

FIGURE 8



## CAN DISPENSER LOADING

### CAN DISPENSER (OPTIONAL)

The can dispenser is used to dispense cans of soda or by using the two tray guides for dispensing microwave type tubs. The unit is mounted in place of one of the large (snack) helix and can hold five to six cans of soda or microwave tubs depending on the size of the container.

### LOADING INSTRUCTION

Release the white tab on the right hand side of the helix tray. Lift up and pull the tray all the way out until it comes to the stop. Lower the tray into the loading position. Lay the cans or tubs on their side so that they will roll down the tray. The figure below shows the proper way to load a microwave tub. Notice that the bottom of the microwave tub sits on a small shelf that keeps the tub level as it rolls down the tray. See figure 9 below.

Note: The adjustable tray sides will have to be installed and adjusted for dispensing the microwave tubs. To adjust the trays, if they are already installed, loosen the two screws holding the sides in place and adjust the sides so that there is approximately 3mm of clearance on each side of the tub when it is placed in the tray. The tub should not bind up when it rolls down the tray. To dispense cans of soda remove the two adjustable tray sides from the dispenser.

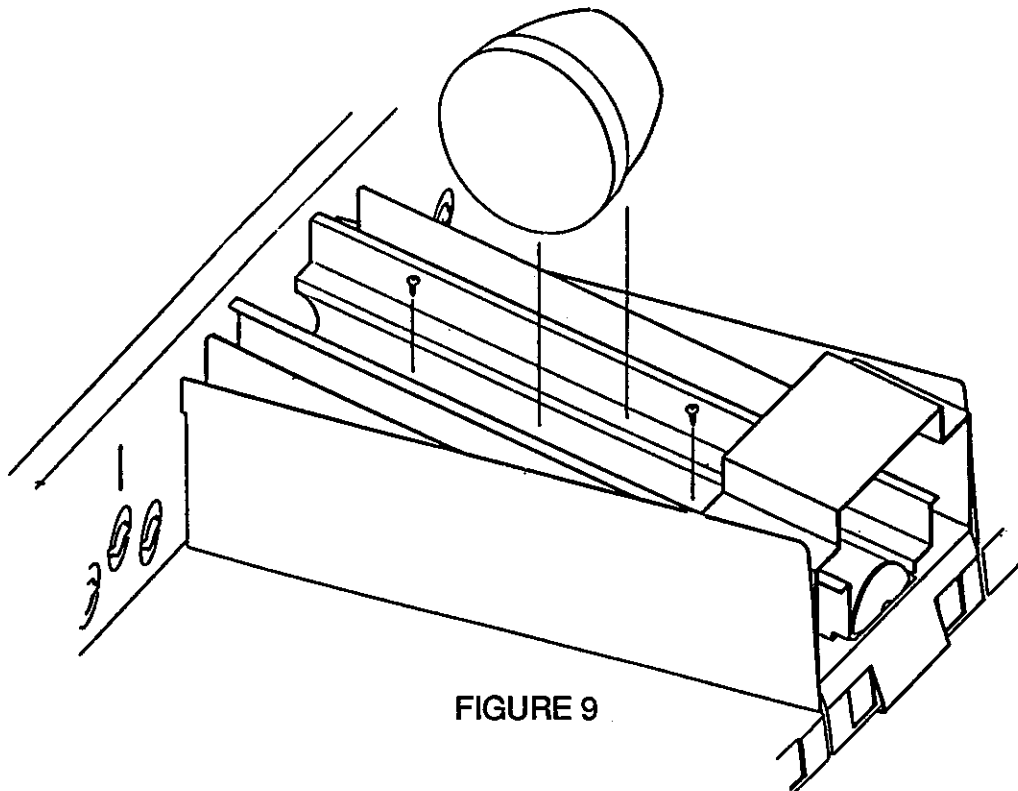

FIGURE 9



## PRIMARY CABINET COMPONENT INFORMATION

### SLIDEOUT CONTROL DRAWER

All electrical components in this compartment are low voltage. Located in this panel are the control board, changer, power interlock and digital readout circuit board. The 220-240VAC transformer, chiller plug, light ballast, light starter and fuses are located in the high voltage electrical box located in the back of the storage area attached to the right rear brace (See Figure 11). Note: Power is shut off when the slideout drawer is pulled out. To apply power to the drawer, pull the interlock switch plunger out. See figure 10 for location.

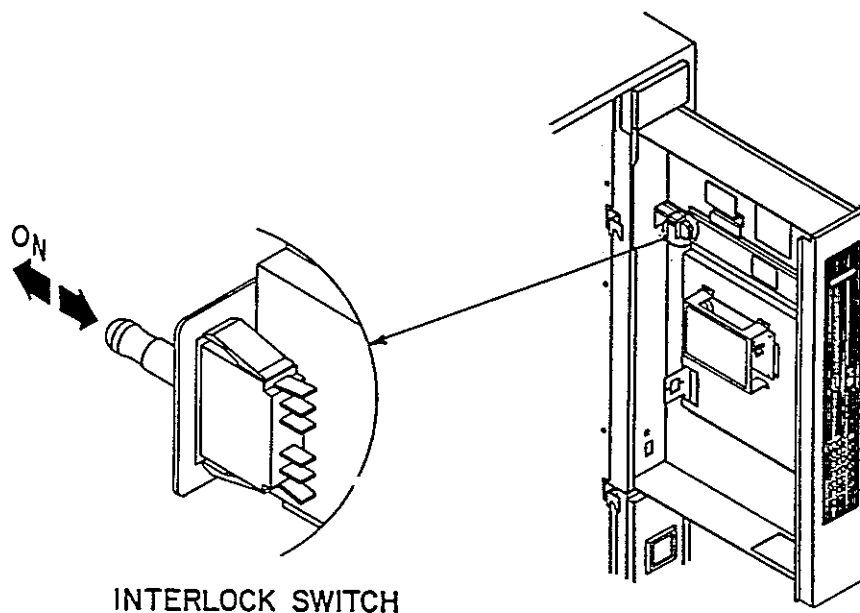

FIGURE 10

### REMOVAL OF SLIDEOUT DRAWER

With the service door open, pull the slideout drawer to the stop. Reach up from the storage area to the rear of the slideout drawer and unplug the three harness connections from the rear of the drawer. Note: The slideout drawer may have to be pushed partially closed, in order to reach the back of the drawer and disconnect the wiring harness. After disconnecting the harness, pull the drawer to full open position. Remove the four (4) screws from the slide in the center of the drawer. Two of the screws must be removed through the large hole in the center of the slide section. Be careful and **DO NOT ALLOW THE DRAWER TO FALL** when removing these screws. Lift and remove the drawer from the guides. For installation of the drawer reverse the procedure.



## REAR ACCESS PANEL

A large access panel is provided on the rear of the machine. Its only purpose is to permit access to the wiring in the rear of the machine. To remove the rear access panel, locate the two keys provided in the spare parts envelope (manila envelope located in the product delivery compartment), insert the keys into the locks on the panel and unlock them. Pull the top away from the cabinet, then lift the bottom of the door away from the cabinet and remove. Handle carefully to prevent dropping and damage. Note: Rear access panel is for convenience only. All service can be handled from the front of the machine.

## STORAGE COMPARTMENT

The storage compartment is below the product display area and is accessed by opening the front door. Be sure to leave room for the delivery compartment when using the storage area. See figure 11.

## HIGH VOLTAGE POWER SUPPLY

The high voltage power supply is located in the bottom of the machine, to the rear of the storage compartment on the right-hand side (See figure 11 below). The fuses for the 10.8 volt, 24 volt, 220-240 volt circuits and the starter for the florescent lamp are located on the front of the power supply. Located on the left side of the power supply is the plug for the chiller unit. Also located inside the power supply are the ballast for the florescent light, the step down transformer and the RFI filter.

## COIN COLLECTION

The coin bank is located in the bottom right hand side of the machine in the storage compartment area and is accessible when the front door is opened. An optional lock and key is available to provide additional security. To open, tilt the top of the bank to the left until it can be removed. Lift and remove coin bank, empty the coins and replace by reversing the procedure. See figure 11 for location.

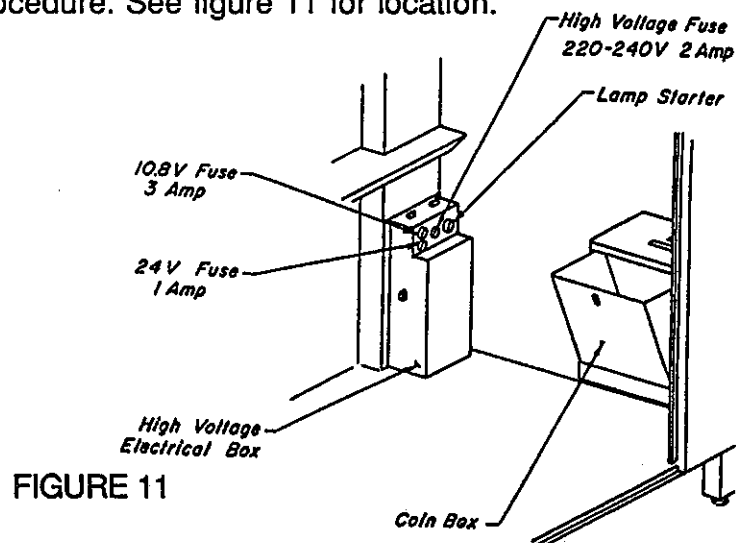

FIGURE 11



## HELIX TRAY REMOVAL (FROM MACHINE)

Lift the white cam on the right side of the helix tray clear of the latch and pull forward until reaching the stop that allows the tray to tilt down for loading. Lift the front of the tray and the same white cam while pulling forward. The tray should then slide out. Unplug the wire harness on the right-hand side rail (Notice how plug is connected, with the wires to the front of the plug). To clear the machine, grasp the tray at the front, back and lift it out and place it on a work surface.

To replace, reverse the operation. Grasp the tray, engage the rear rollers in the track and plug in the wire harness provided on the right rail (Make sure plug is properly connected, wires to the front of the plug). Slide in the tray, raising up the front to clear the stop, and push into the loading position. Lift and push it into the machine until it is in the latched position.

## HELIX DISPENSER REMOVAL

An individual helix can be removed for cleaning, repair or replacement with a different pitch whether the tray is in or out of the machine. Grasp the helix and twist counter clockwise 10 to 15 degrees. Then pull forward and remove the helix from the tray.

To replace the helix, align the tabs on the helix hub with the slots in the white colored tray coupling. Push the helix into position and twist 10 to 15 degrees clockwise as shown below. Verify that the helix end is in the proper position and pull to insure proper connection.

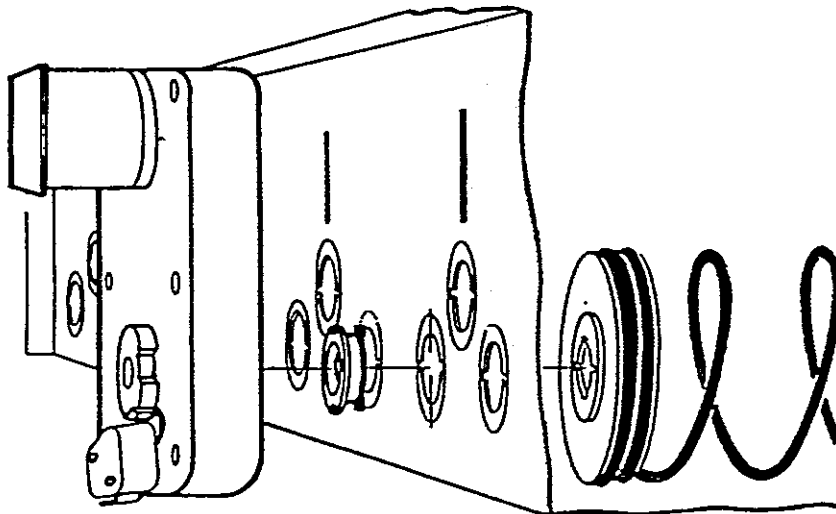



## WEDGE MODULE

The figure below (Figure 12) illustrates the wedge chain dispenser used in the machine.

The Primary Components are:

1. Motor Assembly
2. Module Arm
3. Rack Module and Slide Assembly

When a product selection is made, an electric signal from the selector switch starts the motor and the control board will supply power until the switch signals that the vend is complete. This advances the dispensing chain one step. As the leading chain segment moves around the front sprocket, the hook of the following segment acts as a lever to activate the white slide and lifter of the the front segment forcing the spring loaded cylinders upward. This upward movement releases the wedged grip maintained on the merchandise bag and the bag drops to the delivery compartment, finishing the vend.

A caution was stated in the Wedge Dispenser Product Loading section, warning the user about pulling a product out of the dispenser. If a strong force in the downward direction is used, it will cause the metal cylinders to seat against the plastic dispenser chain segment. The product cannot be released and the module may jam in cycle, which causes the machine to be inoperative. A good indication of someone pulling on a bag is that some of the chain parts are found laying loose in the bottom of the machine. Even if less force is used, the tolerances will be changed, causing eventual failure of the dispensing chain. The correct way to remove a product is actually easier and consists of pushing up on the white-colored release lever immediately behind the product. This causes the product to fall into your hand without damaging the dispenser.

There is a particular type of bag made of glassine material that cannot be vended with the Polyvend wedge chain. This is a coated material that covers the metal cylinders with wax causing the bags to slip out of the wedges freely.

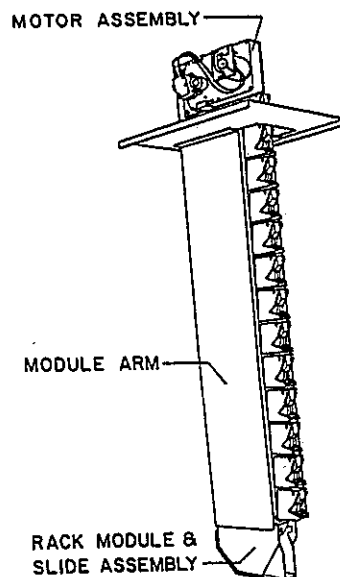

FIGURE 12



## **ELECTRICAL SERVICE SECTION**

### **MODES OF OPERATION**

The system will operate in one of two modes, sales or service. On power up (After completing configuration), the machine is in the sales mode. Service mode may be selected by pressing the mode switch mounted on the control board. The system will return to the sales mode if the mode switch is pressed again or after 25 seconds of no service mode activity.

### **SALES MODE**

In the sales mode, the control board will control the dispensing of products according to customer credit and selection inputs. The control board will communicate with the coin mechanism so as credit is entered it will be shown on the display. If there is inadequate change available, the coin mechanism indicates that an exact change situation exists the control board will show on the scrolling display "PLEASE INSERT EXACT MONEY".

When a customer makes a selection on the key pad, row A to G and (within 5 seconds) numbers 0 thru 9. The accumulated credit will be compared to the price set for this product and if the credit is equal to or exceeds the set price, the corresponding motor will be energized. If the vend is successful the price will be deducted from the credit value and the change returned.

The vend will be considered unsuccessful if the motor exhibits under current or fails to reach the home position within six (6) seconds. The vend will not be attempted if the motor has already been detected as failed or if the selection is not in the configuration of the machine. In any case, credit will not be deducted and the "MAKE ALTERNATE SELECTION" message will be on the scrolling display until a new selection is made.

If there is insufficient credit for the selection made, the selection and price of that selection will be displayed for five (5) seconds, followed by the message "PLEASE INSERT MORE MONEY". This message will be displayed until enough credit is added and the selection made again or a lower price is selected. The correct selection and the selection price will be displayed during the vend.

If power should fail during a vend, the credit will be lost, the selected motor **WILL NOT BE RE-ENERGIZED** when power returns, thus the next vend of this motor may be shorter than normal.





## SERVICE MODE

This mode will be entered by pressing the "MODE BUTTON" located on the control board just above the two red power indicator lights (See Figure 13). By using the numbers and letters on the alphanumeric key pad the operator can program and review the features of the control board. Upon pressing the "MODE BUTTON", the display will sequence through (1.5 secs. each), the alphanumeric selection codes of any motors which the control board believes to have failed and an error code will appear on the right, telling the operator the reason for the failure. Pressing and holding the #13 button will abort this sequence display.

## ERROR CODES

1. Error 1 = To little motor current.
2. Error 2 = To much time to complete the vend (6 secs.).
3. Error 3 = The control board has lost communications with the changer. (Changer has malfunctioned)
4. Error 4 = EEPROM sum check error.

Note: Error 4 = Prices have been inadvertently altered and all prices have automatically been set to maxmiums by the control board. To clear these prices, reset pricing as desired.

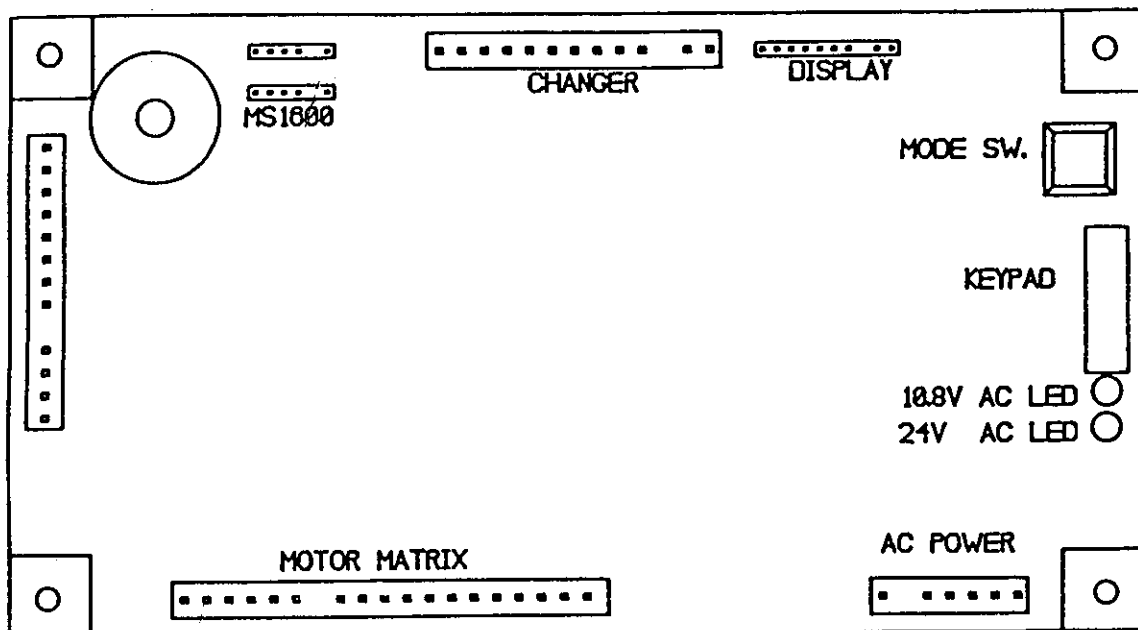

FIGURE 13



## CONTROL BOARD PROGRAM MODES

### ERROR CODES

1. Error 1 = Too little motor current.
2. Error 2 = Too much time to complete the vend (6 seconds).
3. Error 3 = The controller has lost communications with the changer (changer has malfunction).
4. Error 4 = EEPROM sum check error.

Note: Error 4 = Prices have been inadvertently altered and then all prices have automatically been set to maximum by the control board. To clear these prices reset the pricing as desired.

The following is a menu of the program modes available to the operator.

- KEY 0 Not used
- KEY 1 Not used
- KEY 2 To display motor configuration.
- KEY 3 For reconfiguration of the machine.
- KEY 4 Cash accountability  
A = Total cash accountability. This function can not be reset.
- KEY 5 Enter price setting mode.  
Then press 10 = individual price setting.  
11 = price setting by row.  
12 = price setting by entire machine.
- KEY 6 Service vend by individual selection.
- KEY 7 Service vend by row.
- KEY 8 Service vend by entire machine.
- KEY 9 Point of sales message programming.
- KEY 10 Selection of a language.  
Key also used with key 5 for individual price setting.
- KEY 11 Key used with key 5 for price setting by row.
- KEY 12 Key used with key 5 for price setting by entire machine.
- KEY 13 To exit a mode, price setting by row, price setting by machine, service vend by row or service vend by machine.

The operator can exit the service mode by pressing the "MODE BUTTON" on the control board or allow a period of inactivity in excess of 25 seconds to elapse. Either way the machine will return to the sales mode of operation.



## **DETAILED OPERATION OF CONTROL BOARD**

At the time of delivery from Polyvend, the control board will be set as follows:

1. All vend options will be off.
2. The maximum change limit is not used.
3. The cash accountability will be set to \$00,000.00. Note: Due to factory testing the total will not be exactly \$00,000.00.
4. All of the prices will be set \$99.95.
5. The language will be set to English.
6. The point of sales message will be preprogramed to: "ENJOY ONE OF OUR FINE SNACK PRODUCTS".

### **1. MOTOR COUNT**

While in the service mode press button #2 to display the total number of functioning motors. On the display the message "MOTORS" will appear and the total number of motors found.

### **2. MOTOR REMOVAL**

To remove a motor from the configuration while in the service mode, press button #3. The control board will reconfigure to the currently functioning motors. The display will show "CONFIGURED", when completed.

### **3. CASH ACCOUNTABILITY**

To display the stored accountability, while in the service mode, press #4 button. The control board will display "ACCOUNTING" and then press "A".

A = Total cash accountability, which will rollover after \$99.999.95. Note: This function can not be reset.

To exit this mode, either press button #13 or exit the service mode.

### **4. PRICE SETTING**

#### **A. Price Setting of the Entire Machine**

To set the price of the entire machine while in the service mode, press button #5. The control board will display "SELECTION". Then press any letter and number. The scrolling display will show the selection letter and number and the price. Using the numbers on the key pad press the most significant digit first, then the less significant digits. Example: \$00.90. Press button #9, then press button #0. To save this price for the entire machine press button #12. To cancel an unwanted price before the fourth number is entered, press button #13.



## B. Price setting by Row

To set the price of an entire row of selections, press button #5. Then enter a selection from the row you want to set the prices on. The display will show the letter, number and current price. Using the numbers on the key pad, press the most significant number of the price first, followed by the less significant numbers. Example \$00.90. Press the #9 button then press the #0 button. The scrolling display should read \$00.90. In order to save this and set the entire row, press button #11. To set the next row, press button #5. Then enter the letter and number from the next row you want to set the prices on and repeat the price setting procedure. To cancel an unwanted price before the fourth number is entered, press button #13.

## C. Individual Price Setting

To set the price on an item, while in the service mode, press button #5. The scrolling display will show "SELECTION". Press the letter and number of the selection you wish to change. The selection letter and number will be displayed and the current price. Using the numbers on the key pad, press the most significant digit first, then the less significant digits. Example: \$00.85. Press button #8, then button #5. The scrolling display should read \$00.85. To save this price, press button #10. To set another single price, press button #5 and repeat the above price setting sequence. To cancel an unwanted price before the fourth digit is entered press #13.

NOTE: When the price is set to \$00.00 this is allowed and is a service vend (free vend).

The machine can then be used as a display or show machine.

## 5. SERVICE VEND

### A. Service Vend by Individual Selection

To service vend a single selection motor, while in the service mode, press button #6. The scrolling display will show "SELECTION". Enter the desired selection letter followed by the number. This will be displayed with the selection price while a vend of the motor is attempted. If the vend is successful the scrolling display will blank. If the vend is not successful the control board will beep three times before blanking the scrolling display.

### B. Service Vend by Row

To service vend an entire row of selection motors, while in the service mode, press button #7. The scrolling display will show "SELECTION". Enter the letter of the desired row. The scrolling display will show the selection number and price while the vend is attempted, starting with the highest number selection in that row. If the vend is successful the control board will continue with the next motor. If the vend is not successful the control board will beep three times and continue with the next motor. This will be repeated until vends on all motors in the row have been attempted. Then the display will blank.

To exit this mode, either press button #13 and hold until the current vend is completed or exit the service mode.



C. Service Vend of Entire Machine (One complete test).

To service vend the entire machine of selection motors one time, while in the service mode, press button #8. The scrolling display will show the selection number and price, as the corresponding vend is attempted. If the vend is successful, the control board will continue on with next motor. If the vend is not successful the control board will beep three times and continue with the next motor. This cycle will be repeated until vends on all motors in the machine have been attempted. The display will then blank.

To exit this mode, either press button #13 and hold until the current vend is completed or exit the service mode.

6. POINT OF SALES MESSAGE PROGRAMMING

The machine comes preset from the factory with the message "ENJOY ONE OF OUR FINE SNACKS".

If you wish to change the Point of Sales message, press the service mode button on the control board, then press button #9. The scrolling display will show "MESSAGE". Using the keypad overlay (provided with each machine) and following the keypad definitions, enter the new message. Menu 1 is the default menu. After each keypad entry, from either menu, the keypad will return to menu 1. To use menu 2, the "SHIFT" key must be pressed prior to pressing a menu 2 key. Put two (2) spaces to indicate the end of the message. To save the message the "ENTER" button must be pressed from within menu 2.

Note: The maximum number of characters you can enter to form a message is 53 characters plus two spaces at the end of the message. The two spaces are to prevent the end and the beginning of the next message from running together. A space between two words is one character.

MENU 1			MENU 2		
A	G	M	S	Y	4
B	H	N	T	Z	5
C	I	O	U	0	6
D	J	P	V	1	7
E	K	Q	W	2	8
F	L	R	X	3	9
SPACE	SHIFT	BACK	*	ENTER	\$
	(NEXT MENU)	SPACE			

EXAMPLE: "ENJOY OUR SNACKS". Press button #9, "MESSAGE" appears on display. Using the overlay press the letter E, letter N, letter J, letter O, press SHIFT, press Y, press SPACE, press 0, press SHIFT, press U, press R, press SPACE, press SHIFT, press S, press N, press A, press C, press K, press SHIFT, press S, press SPACE, press SPACE, press SHIFT, press ENTER. The message should start scrolling when you press the mode switch. To remove a wrong letter press backspace.



## 7. Language Selection

To select the message language, while in the service mode, press button #10. The scrolling display will show "LANGUAGE". Press the letter of the language you want to program in (See list below). The language selected will be displayed.

- Press button #10 + button A = Italian
- Press button #10 + button B = Dutch
- Press button #10 + button C = Spanish
- Press button #10 + button D = Danish
- Press button #10 + button E = English
- Press button #10 + button F = French
- Press button #10 + button G = German

Note: The language you select will be for "Exact Change Only", "Please Insert More Money", etc.. It will not translate the Point of Sales message on the scrolling display.





## **CLEANING INSTRUCTIONS**

### **PAINTED SURFACES**

All painted surfaces and the vinyl covered product delivery door can be cleaned with a clean cloth and any common brand of household detergent. Do not use harsh abrasive materials on these surfaces, they will scratch the paint or vinyl.

### **GLASS ITEMS**

The glass product loading door may be cleaned with any commercial window cleaner.





## WEDGE MODULE CHAIN REPLACEMENT

Occasionally the dispensing chains must be replaced or repaired. These chains are timed and synchronized at the time of installation and must be **REMOVED WITH CARE**. Figures 14-26 show the sequence of operations to accomplish this.

Release the latch on the dispenser and pull slide out to its stop. (Fig. 14).

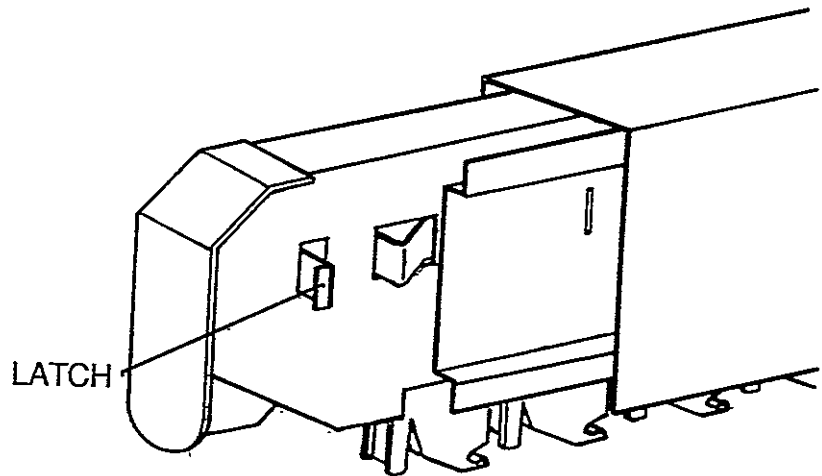

FIGURE 14

Remove the dispenser number and price cover. (Fig 15)

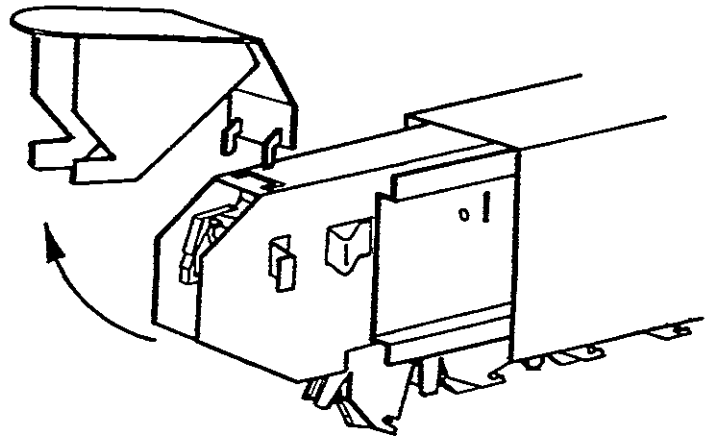

FIGURE 15



Remove the screw from the side of the dispenser (Fig. 16) which serves as the stop and pull slide from the machine.

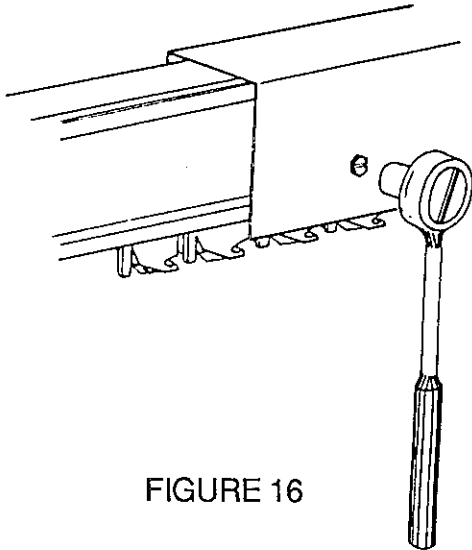

FIGURE 16

Release the detent spring by pushing the flat end down and pulling it out from under the detent spacer. Fig. 17.

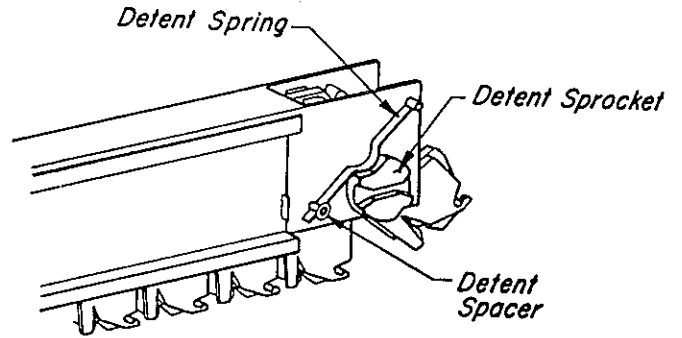

FIGURE 17

Still holding slide vertical, lift bottom of chain outward and away from the slide. Push upward allowing the chain to slide free. (Fig. 18).

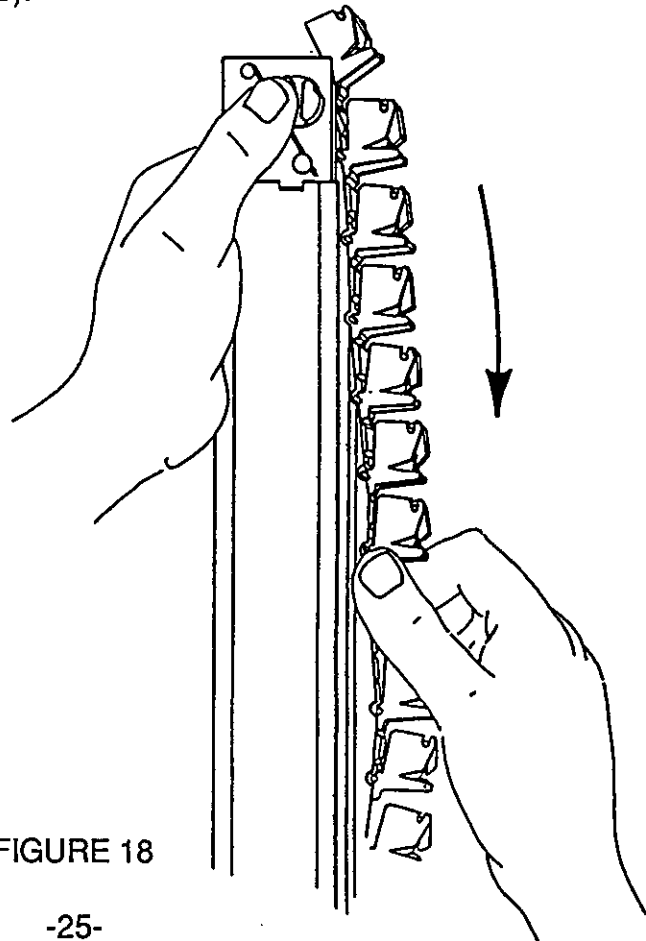

FIGURE 18



Point front end of slide up and grasp the chain with thumb and fingers. Pull the chain support slide while rotating the chain backward to normal rotation. Repeat until eight(8) support pins are on top of the slide, which allows enough slack to unhook the chain. (Fig. 19)

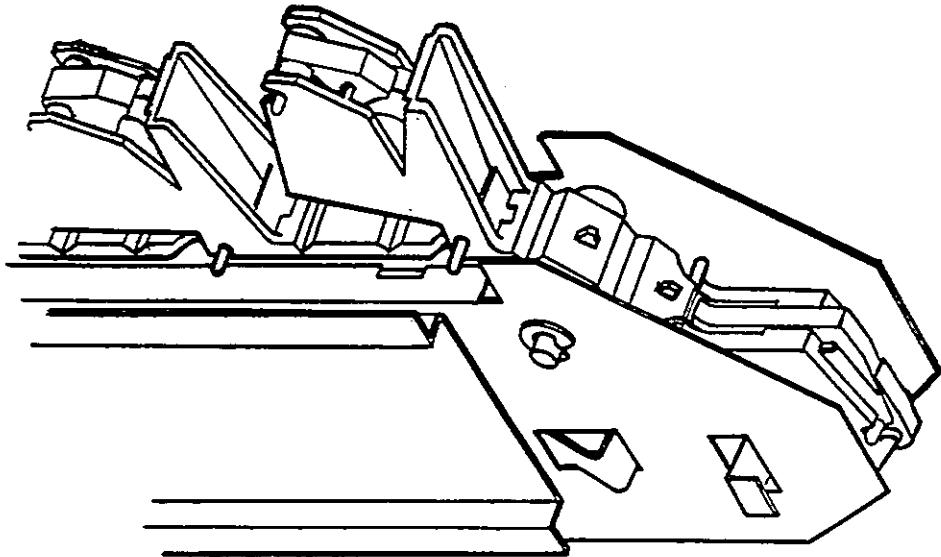

FIGURE 19

Unhook chain by grasping one link near the support pin and the next link near the snap connector, then gently twist the chain until it snaps loose. (Fig. 20).

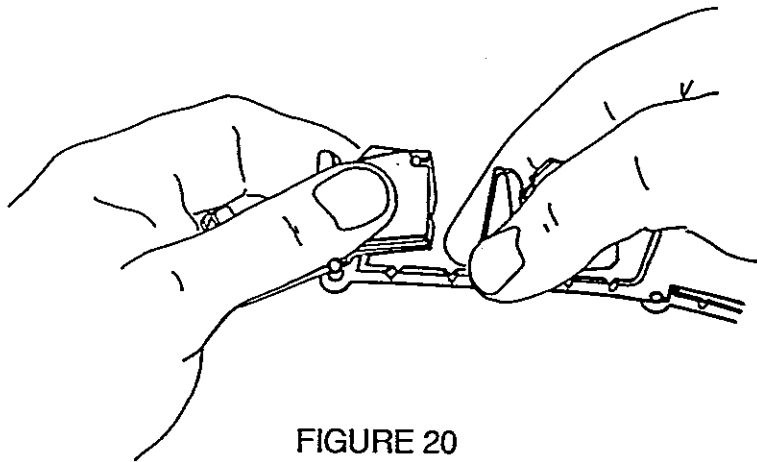

FIGURE 20



Hold slide vertical with the front end up and the chain will fall free of the inner portion of the slide. (Fig. 21). To repair the wedge assembly see section on wedge assembly repair page 30.

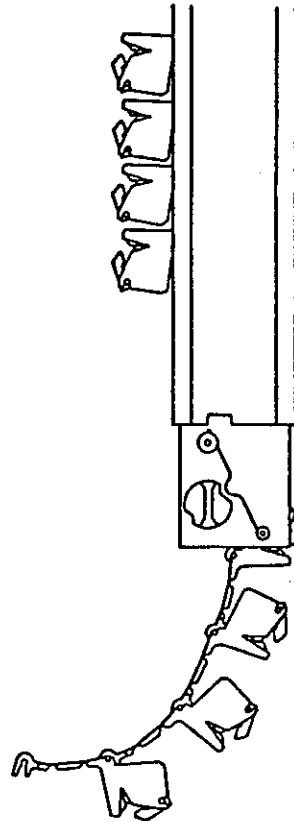

FIGURE 21

To replace chain, lay dispenser on its top and insert the chain end through the front of the module. The snap connector end must be inserted from the front as shown or chain rotation will be wrong. Continue pushing the chain through the dispenser until equal lengths of chain are sticking out each end. (Fig. 22).

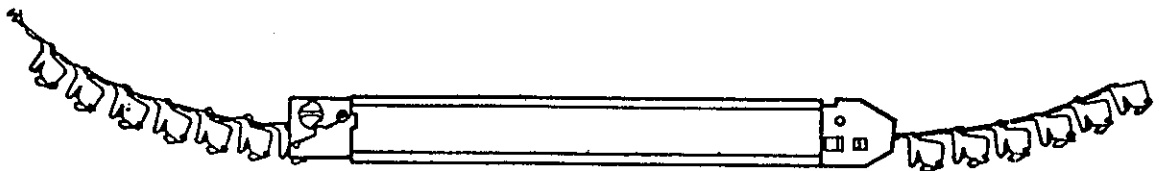

FIGURE 22



To time the chain, re-engage the detent spring by turning the sprocket to the detent position and pushing the detent spring end under the detent spacer post. Align a support pin with the BACK edge of the module. DURING THE NEXT STEP, be careful NOT to move the chain forward or backward as this would misalign the support pin and therefore, chain timing would be wrong. (Fig. 23).

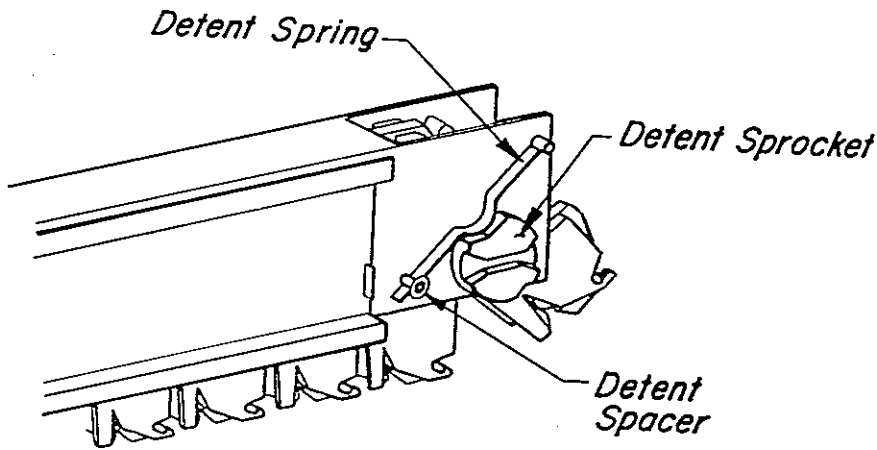

FIGURE 23

Grasp both ends of the chain and pull it over the bottom of the module. Push the white color slide out of the way and push the snap connector on to the support pin (Fig. 24).

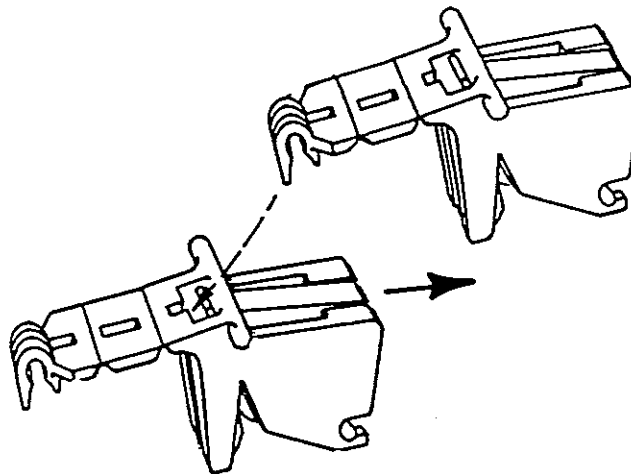

FIGURE 24



To place the chain guide in the chain support slide, grasp the chain with one hand and rotate it in the direction of NORMAL rotation, while pushing in on the detent sprocket (to prevent it from coming out of the arm) with one thumb. (Fig. 25).

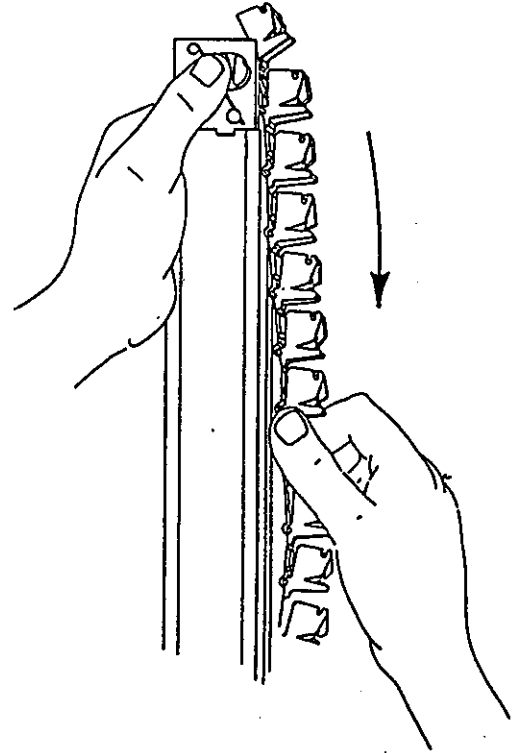

FIGURE 25

Continue pulling the chain until three (3) complete revolutions have been made. With the detent spring in the detent position, the leading chain segment will be in the position shown if the timing is correct. (Fig. 26).

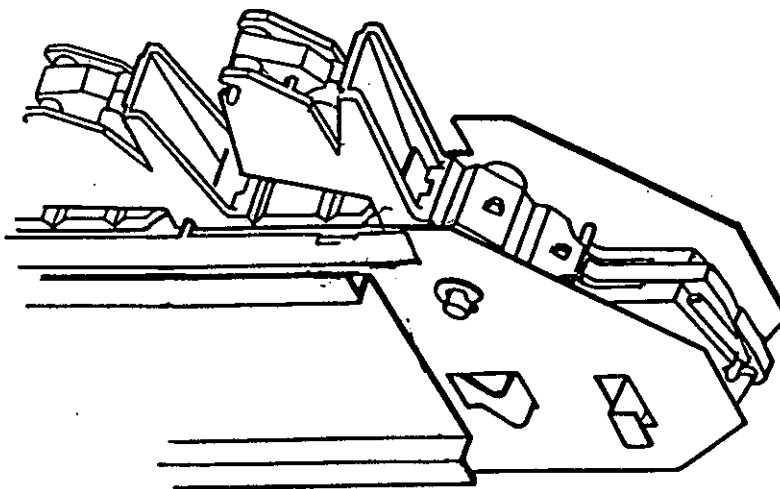

FIGURE 26

Install the dispenser into the arm. Place the screw that serves as the stop back in the arm. Slide the dispenser in until the locking latch engages.



## WEDGE ASSEMBLY REPAIR

To repair the assembly and replace damaged components, remove the chain and snap out the damaged link.

This link is made up of the basic chain housing segment (Black in color), a cylinder lifter (White in color), a slide (White in color), two cylindrical wedge components and a compression spring. (Fig. 27).

To disassemble the link, hold the unit between both hands and push the cylinder lifter stub shafts outward with both thumb nails. It will pop out (retain with fingers) and may be removed. Take care the compression spring isn't lost as the slide is removed. Now, the spring will fall free and the cylindrical wedge components will follow when the link is inverted. When reassembling the lifter, be sure the "flat" edge is against the cylinder wedge and not against the slide.

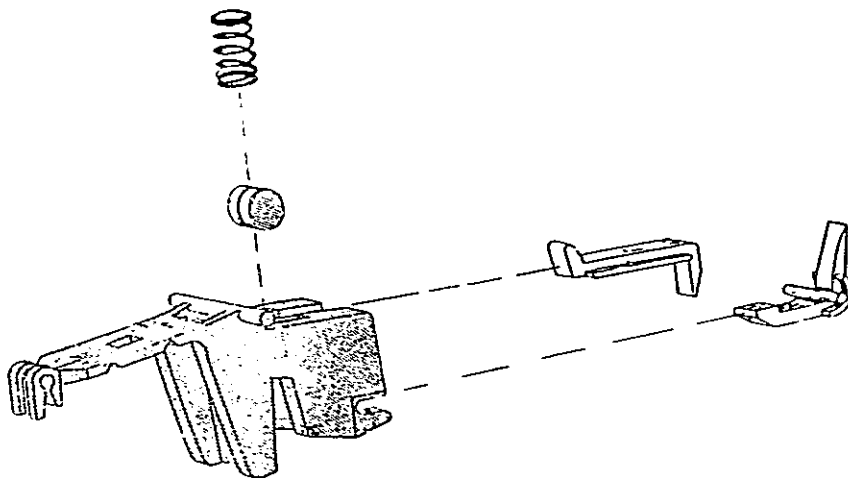

FIGURE 27

All that remains is to reassemble using the replacement parts as necessary. When the link has been repaired, snap it back on the chain and reassemble the chain as covered by the assembly instructions on pages 27 thru 29.



## TROUBLE SHOOTING

### CAUTION

BEFORE CHANGING, DISCONNECTING OR CONNECTING ANY ELECTRICAL COMPONENTS, DISCONNECT POWER TO THE MACHINE BY TURNING OFF THE INTERLOCK SWITCH, REMOVING THE FUSES OR UNPLUG THE MACHINE FROM THE WALL.

SYMPTOM	PROBABLE CAUSE	CORRECTIVE ACTION
<p>1. All coins deposited are rejected</p> <p>In service mode error code 3 displayed</p> <p>10.8 volt and 24 volt power indicator L.E.D.'s not on.</p>	<p>Machine not level</p> <p>Defective coin mechanism</p> <p>Display blank, no power</p> <p>Defective control board assembly.</p>	<p>Level machine</p> <p>Replace mechanism</p> <p>Check fuses, transformer and power at wall outlet</p> <p>Replace control board. See note 2.</p>
<p>2. Selection motor fails to run</p> <p>In service mode error code 2 displayed</p>	<p>Insufficient credit established.</p> <p>Defective motor assembly</p> <p>Defective control board assembly</p> <p>Wire connector disconnected from motor.</p> <p>Wire pinched or broken</p>	<p>Check to see that selection price is same as deposited amount. Note message on display.</p> <p>Test vend bad motor. Replace if defective See note 1 below.</p> <p>Replace assembly See note 2 pg. 32.</p> <p>Reconnect wire on motor.</p> <p>Trace wire harness for broken or pinched wire. See note 3 pg. 32.</p>
<p>3. All selection motors do not run (Test or service vend)</p>	<p>Defective control board</p> <p>Connection broken</p>	<p>Replace assembly See note 2 pg. 32.</p> <p>Trace wire harness, See note 3 pg. 32.</p>

Note 1: When you replace a motor, service vend the new motor to tell the control board a new motor has been installed.





SYMPTOM	PROBABLE CAUSE	CORRECTIVE ACTION
<p>4. Selection motor does not complete cycle in service mode shows error code 1 or 2.</p>	<p>Defective full cycle switch or defective motor assembly.</p> <p>Defective components on motor PC board assembly</p> <p>Defective control board assembly</p>	<p>Replace motor assembly See note 1 pg. 31.</p> <p>Replace motor assembly See note 1 pg. 31.</p> <p>Replace assembly See note 2 below</p>
<p>5. Selection motor continuously cycles</p>	<p>Defective full cycle switch</p> <p>Defective control board assembly</p>	<p>Replace motor See note 1 pg. 31.</p> <p>Replace control board assembly See note 2 below.</p>
<p>6. Two motors run simultaneously</p>	<p>Defective control board assembly</p> <p>Defective motor assembly</p>	<p>Replace assembly See note 2 below.</p> <p>Replace assembly</p>
<p>7. Incorrect change dispensed, in service mode error 3 displayed</p>	<p>Defective coin mechanism</p> <p>Defective control board assembly</p>	<p>Replace mechanism</p> <p>Replace control board. See note 2 below.</p>
<p>Note 2: When you replace the control board always disconnect power to the equipment. After control board is installed, go into the service mode and press button #13, then press button #2, then press button #3. You have now aligned the control board with the motor configuration of the machine.</p> <p>Note 3: The motors in the machine are arranged in a 7 X 10 matrix. This means that all motors have a wire common to all other motors in that row. Example: All motors in the "A" row have the white with black stripe in common. Likewise, all the motors in a column have a wire in common. Example: All motors in column 2 have a red wire in common. To trace the common wire see wiring chart next page.</p>		



## WIRING COLOR

The following is the wire color guide for the motor matrix:

	WIRE COLOR
Row "A"	White/Black
Row "B"	White/Brown
Row "C"	White/Red
Row "D"	White/Orange
Row "E"	White/Yellow

The following wires are located in a separate two pin plug of the harness that plugs into the pull out drawer.

Row "F"	White/Black
Row "G"	White/Orange

Tray harnesses use only the White/Black wire since they can be used in any row.

Column "0"	Black
Column "1"	Brown
Column "2"	Red
Column "3"	Orange
Column "4"	Yellow
Column "5"	Green
Column "6"	Blue
Column "7"	Violet
Column "8"	Gray
Column "9"	White

SYMPTOM	PROBABLE CAUSE	CORRECTIVE ACTION
When you enter service mode selection number shown with error code.	Motor disconnected  Defective motor  Motor jammed	Reconnect motor  Replace motor  Free jammed motor

### ERROR CODES

1. Error 1 = Too little motor current.
2. Error 2 = Too much time to complete the vend (6 seconds).
3. Error 3 = The control board has lost communications with the changer (changer has malfunctioned).
4. Error 4 = EEPROM sum check error.

Note: Error 4 = Prices have been inadvertently altered and all prices have automatically been set to maximum by the control board. To clear these prices, reset pricing as desired.



# PARTS LISTS

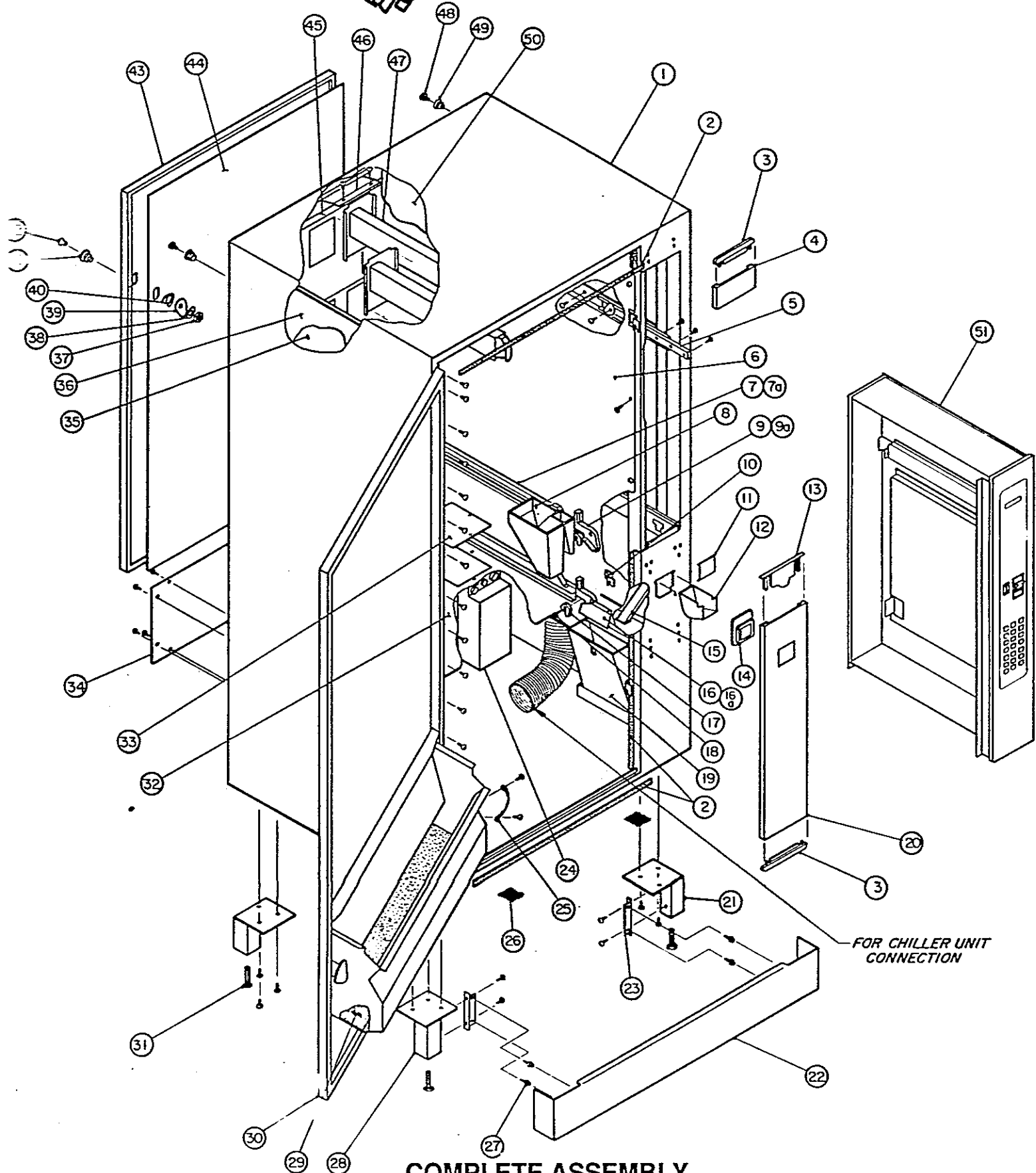

**COMPLETE ASSEMBLY  
TO BE USED IN CONJUNCTION WITH PAGES 35 AND 36**



**PARTS LIST  
COMPLETE ASSEMBLY**

ITEM	DESCRIPTION	PART NO. FULL SIZE	PART NO. MID-SIZE	QTY
1	CABINET *	19824	19853	1
2	NEOPRENE STRIP	810-00	810-00	1485mm
3	ESCUTCHEON END CAP	17917-BLK	17917-BLK	1
4	UPPER ESCUTCHEON PLATE	17939-BLK	17939-BLK	1
5	DRAWER SLIDE	17964	17964	1
6	RT. INNER PANEL	18902-BLK	18902-BLK	1
7	RT. RAIL ASSY.	19697-BLK	19697-BLK	-
7A	LT. RAIL ASSY.	19397-BLK	19397-BLK	-
8	COIN HOPPER	17823	17823	1
9	RT. TRAY LEAD IN	18828	18828	-
9A	LT. TRAY LEAD IN	18829	18829	-
10	SERVICE DOOR LOCK PLATE	17996-BLK	17996-BLK	1
11	COIN CUP DOOR	17865	17865	1
12	COIN RETURN CUP	17866	17866	1
13	MID-ESCUTCHEON CAP	17916	17916	1
14	COIN RETURN TRIM	17868	17868	1
15	COIN BANK CHUTE	17889	17889	1
16	RT. PRODUCT DEFLECTOR	20128-BLK	20128-BLK	1
16A	LT. PRODUCT DEFLECTOR	20127-BLK	20127-BLK	1
17	TRAY LATCH CAM	18697	18697	1
18	HEX - SOCKET SCREW	18827	18827	-
19	COIN BANK	17960-BLK	17960-BLK	1
20	LOWER ESCUTCHEON PLATE	17936-BLK	17936-BLK	-
21	LEG & PLATE ASSY. R.H.	18747-R.H.	18747-R.H.	2
22	KICK PLATE	20062-FBK	20062-MBK	1
23	KICK PLATE MOUNTING BRACKET	19296	19296	2
24	POWER BOX ASSEMBLY	19992-CHT	19993-CHT	1
25	DOOR STOP WIRE CABLE STYLE	18907	18907	1
	DOOR STOP CHANNEL STYLE MADE UP OF PARTS ON DIAGRAM PAGES 40 & 41			
26	FIBER GLASS SCREEN	760-02	760-02	5
27	SCREW	1868-BLK	1868-BLK	8
28	LEG & PLATE ASSY. L.H.	18747-L.H.	18747-L.H.	2
29	DELIVERY PAD	19402-01	19402-01	1
30	DOOR ASSEMBLY	18040 *	18759 *	1
31	LEG LEVELER	19765	19765	4
32	FALSE BOTTOM	18996-BLK	18995-BLK	1
33	FALSE BOTTOM COVER	19009-BLK	19009-BLK	1
34	REAR COVER PLATE	18155 *	18155 *	1
35	STYROFOAM W/BLACK VINYL	19583-01	19583-01	1
36	L.H. INNER PANEL	19280-BLK	19280-BLK	1
37	HEX NUT	347	347	2
38	WASHER	345	345	2
39	CAM LOCK	570	570	2
40	STEEL CLIP	348	348	2
41	REAR DOOR LOCK	10345-01	10345-01	2
42	KEY PD-20	343-01	343-01	2
43	REAR ACCESS DOOR	17819 *	18498 *	1
44	STYROFOAM W/BLACK VINYL	19583-02	19583-02	1
45	MODULE MOTOR PANEL	19858-BLK	19858-BLK	1
46	MOTOR BOARD SUPPORT	18413-BLK	18413-BLK	1



47	RACK MODULE ARM ASSEMBLY	17777-BLK	17777-BLK	-
48	BOLT 1/4 X 1/2 - 20	83271	83271	2
49	1/4 - 20 AVDEL NUT	81089	81089	2
50	STYROFOAM W/ BLACK VINYL	19583-03	19583-03	1
51	DRAWER ASSEMBLY	19787-CHT	19787-CHT	2

\*When ordering part, state whether machine color is brown, white or grey in color.



**CHILLER ASSEMBLY**

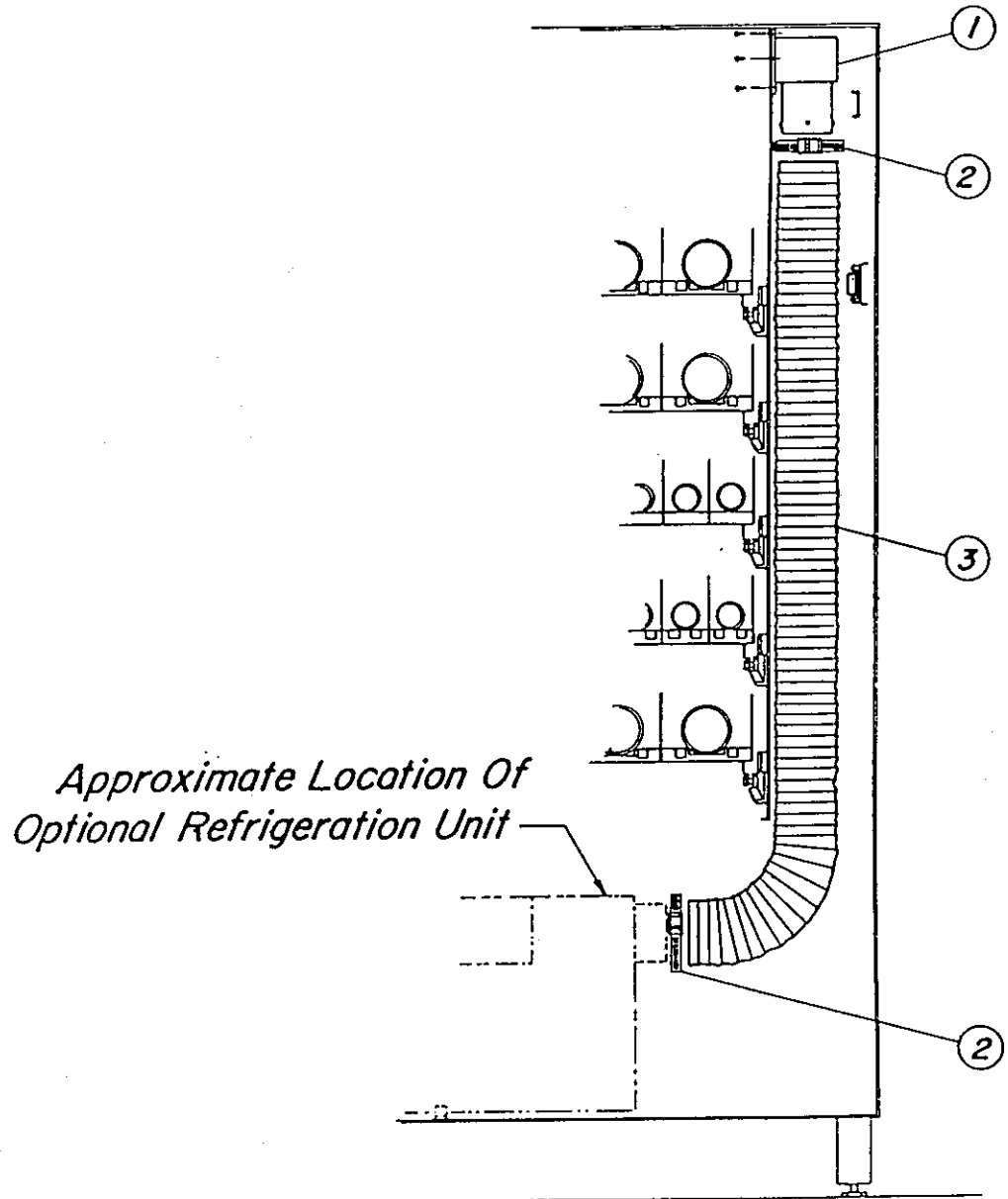

ITEM	PART NO.	DESCRIPTION	QTY
1	19566-BLK	TRANSITION, REFRIG.	1
2	19693	CLAMP, HOSE	2
3	19691	TUBING, FLEXIBLE, 4	1
-	1298-BLK	SCREWS, 8 - 1/8 X 3/8 TAP	6

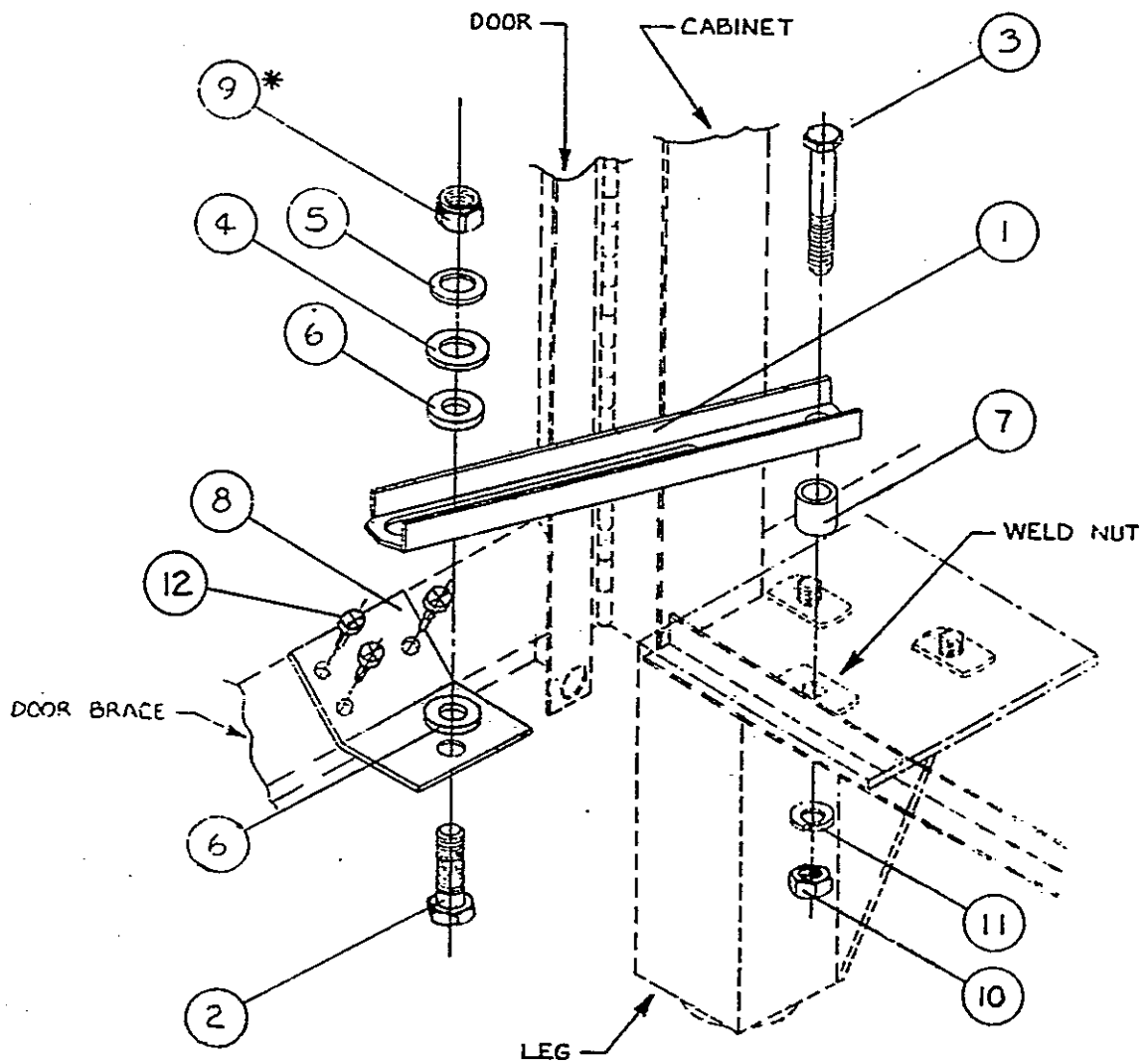

\* NOTE: ADJUST LOCK NUT FOR  $3 \pm 1$  LBS. OPENING/CLOSING FORCE MEASURED AT DOOR EDGE OPPOSITE OF HINGE.

### DOOR STOP ASSEMBLY





**PARTS LIST  
DOOR STOP ASSEMBLY  
CHANNEL STYLE**

ITEM	DESCRIPTION	PART NO.	QTY
1	DOOR STOP CHANNEL	20175	1
2	HEX HEAD BOLT 3/8-24 X 1 1/4	20176	1
3	HEX HEAD BOLT 5/16-18 X 2 1/4	20177	1
4	PRECISION WASHER	20178	1
5	BELLEVILLE WASHER	20179	1
6	NYLON WASHER	20180	2
7	DOOR STOP SPACER	20181	1
8	DOOR BRACKET	20182	1
9	LOCK NUT	20196	1
10	NUT	14937	1
11	SPLIT WASHER	285	1
12	SCREW 10-24 X 5/16	13140	3

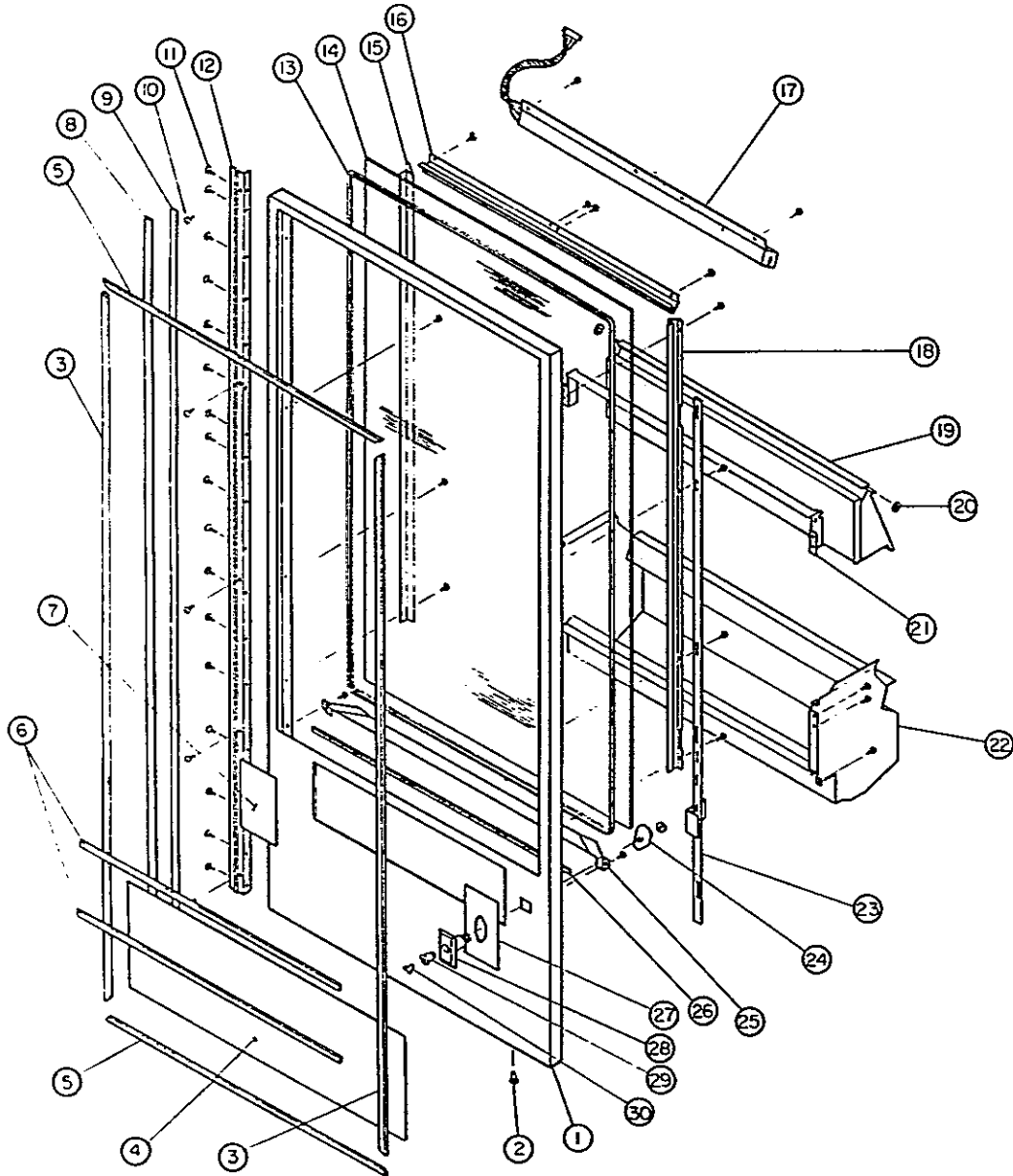

**SERVICE DOOR ASSEMBLY  
TO BE USED IN CONJUNCTION WITH PAGES 41 AND 42**



**PARTS LIST  
SERVICE DOOR FULL SIZE MACHINE  
4000, 5000 AND 6000 SERIES**

ITEM	DESCRIPTION	PART NO.	PART NO.	PART NO.	QTY
		WHITE MACH.	BROWN MACH.	DARK GREY MACH.	
-	COMPLETE ASSEMBLY	18040-WHT	18040-DB	18040-DG	1
1	DOOR FRAME	17924-WHT	17924-DB	17924-DG	1
2	RETAINING PLUG	18442	18442	18442	1
3	R.H. & L.H. TRIM	17956-BLK	17956-GT	17956-BLK	1
4	LOWER DOOR PANEL	-	18102	-	1
5	DOOR TRIM BOTTOM & TOP	17957-BLK	17957-GT	17957-BLK	2
6	DELIVERY COMP. TRIM	17967-BLK	17967-GT	17967-BLK	1
7	DECOR PANEL LEFT SIDE	19983-BLK	19983-BLK	19983-BLK	1
8	HINGE COVER	19359-WHT	19359-WHT	19359-WHT	1
9	TWO SIDED TAPE	18880	18880	18880	147.3MM
10	SCREW #8-32X3/8 TAP	ST-638	ST-638	ST-638	22
11	SCREW #8-18X1/4 TAP	1868-BLK	1868-BLK	1868-BLK	11
12	SERVICE DOOR HINGE	18774-WHT	18774-DB	18774-DG	1
13	SERVICE DOOR GASKET	17970	17970	17970	71MM
14	SERVICE DOOR GLASS	18221	18221	18221	1
15	LEFT GLASS HOLDER	17954-BLK	17954-BLK	17954-BLK	1
16	TOP GLASS HOLDER	17934-BLK	17934-BLK	17934-BLK	1
17	LIGHT FIXTURE	19707	19707	19707	1
17A	LAMP BULB	18858	18858	18858	1
17B	LIGHT DEFLECTOR	18838-WHT	18838-WHT	18838-WHT	1
17C	LAMP BRACKET	19707	19707	19707	1
17D	HARNES	19706	19706	19706	1
17E	SCREW	2614-BLK	2614-BLK	2614-BLK	1
17F	SCREW	1298-BLK	1298-BLK	1298-BLK	1
18	RIGHT GLASS HOLDER	17954-BLK	17954-BLK	17954-BLK	1
19	PRODUCT DELIVERY DOOR	19986-E	19986-E	19986-E	1
20	NYLON WASHER	18684	18684	18684	2
21	PRODUCT DELIV. HINGE CV.	18629-BLK	18629-BLK	18629-BLK	1
22	PRODUCT DELIVERY COMP.	18260	18260	18260	1
23	LOCKING BAR	18001-BLK	18001-BLK	18001-BLK	1
24	CAM LOCK	17457-BLK	17457-BLK	17457-BLK	1
25	PRODUCT DEFLECTOR	20126-FBK *	20126-FBK *	20126-FBK *	1
26	NEOPRENE STRIPPING	18245-00	18245-00	18245-00	61MM
27	DECOR PANEL RT. SD.	19982	19982	19982	1
28	LARGE LOCK ASSEMBLY	19379-BLK	19379-BLK	19379-BLK	1
29	LOCK CYLINDER INSERT	19380-02	19380-02	19380-02	1
30	LOCK KEY	11527-02	11527-02	11527-02	2

\* DEFLECTOR SURFACE NORMALLY BLACK. TO ORDER SHINY SURFACE ORDER PART NO. 20249-02 WITH PART NO. 20126-F00.



**PARTS LIST  
MID-SIZE MACHINE  
LONG GLASS IN DOOR  
4000M, 5000M AND 6000M**

ITEM	DESCRIPTION	PART NO. WHITE	PART NO. BROWN	PART NO. DARK GREY	QTY
-	COMPLETE ASSEMBLY	18759-WHT	18759-DB	18759-DG	1
1	DOOR FRAME	18721-WHT	18721-DB	18721-DG	1
2	RETAINING PLUG	18442	18442	18442	1
3	R.T. SIDE TRIM	17956-BLK	17956-BLK	17956-BLK	1
4	LOWER DOOR PANEL	-	18778-01	-	1
5	DOOR TRIM TOP & BTM.	18501-BLK	18501-BLK	18501-BLK	1
6	DEL. COMPARTMENT TRIM	18502-BLK	18502-BLK	18502-BLK	1
7	DECOR PANEL LT. SD.	19983-BLK	19983-BLK	19983-BLK	1
8	HINGE COVER	19359-WHT	19359-WHT	19359-WHT	1
9	TWO SIDED TAPE	18880	18880	18880	147.3MM
10	SCREW #8-32X3/8 TAP	ST-638	ST-638	ST-638	22
11	SCREW #8-18X1/4 TAP	1868-BLK	1868-BLK	1868-BLK	11
12	HINGE	18774-WHT	18774-DB	18774-DG	1
13	SERVICE DOOR GASKET	17970	17970	17970	853MM
14	SERVICE DOOR GLASS	18761	18761	18761	1
15	GLASS HOLDER LT. SD.	17954-BLK	17954-BLK	17954-BLK	1
16	GLASS HOLDER TOP	18499-BLK	18499-BLK	18499-BLK	1
17	LIGHT FIXTURE	18671	18671	18671	1
17A	LIGHT BULB	18845	18845	18845	1
17B	DEFLECTOR	18816-WHT	18816-WHT	18816-WHT	1
17C	BRACKET	18815	18815	18815	1
17D	WIRE HARNESS	18670	18670	18670	1
17E	SCREW	2614-BLK	2614-BLK	2614-BLK	2
17F	SCREW	1298	1298	1298	2
18	GLASS HOLDER RT.SD.	17954-BLK	17954-BLK	17954-BLK	1
19	PROD. DELIVERY DOOR	19987	19987	19987	1
20	NYLON WASHER	18684	18684	18684	2
21	PROD. DELIV. DOOR RET.	18672	18672	18672	1
22	PRODUCT DELIVERY COMP.	18492	18492	18492	1
23	LOCKING BAR	18001	18001	18001	1
24	CAM LOCK	17454	17454	17454	1
25	PRODUCT DEFLECTOR	20126-MBK *	20126-MBK *	20126-MBK *	1
26	NEOPRENE STRIP	18245-00	18245-00	18245-00	732MM
27	DECOR PANEL RT. SD.	19982	19982	19982	1
28	LARGE LOCK ASSY.	19379	19379	19379	1
29	LOCK CYLINDER INSERT	19380-02	19380-02	19380-02	1
30	LOCK KEY	11527-02	11527-02	11527-02	2

\* DEFLECTOR SURFACE NORMALLY BLACK. TO ORDER SHINY SURFACE ORDER PART NO. 20249-03 WITH PART NO. 20126-M00.



## HELIX ASSEMBLY

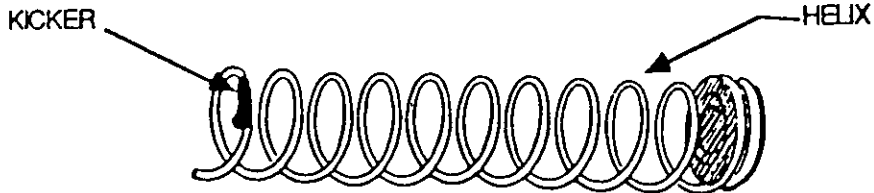

SNACK			CANDY		
HELIX	PART NO.	PRODUCT THICKNESS	HELIX	PART NO.	PRODUCT THICKNESS
14 CT	18374-02	25.4mm	22 CT	18372-09	15.9mm
10 CT	18374-04	38.1mm	14 CT	18372-01	25.4mm
8 CT	18374	47.6mm	12 CT	18372-03	31.75mm
			10 CT	18372-02	38.1mm
SEPARATE KICKER 18303			SEPARATE KICKER 18302		

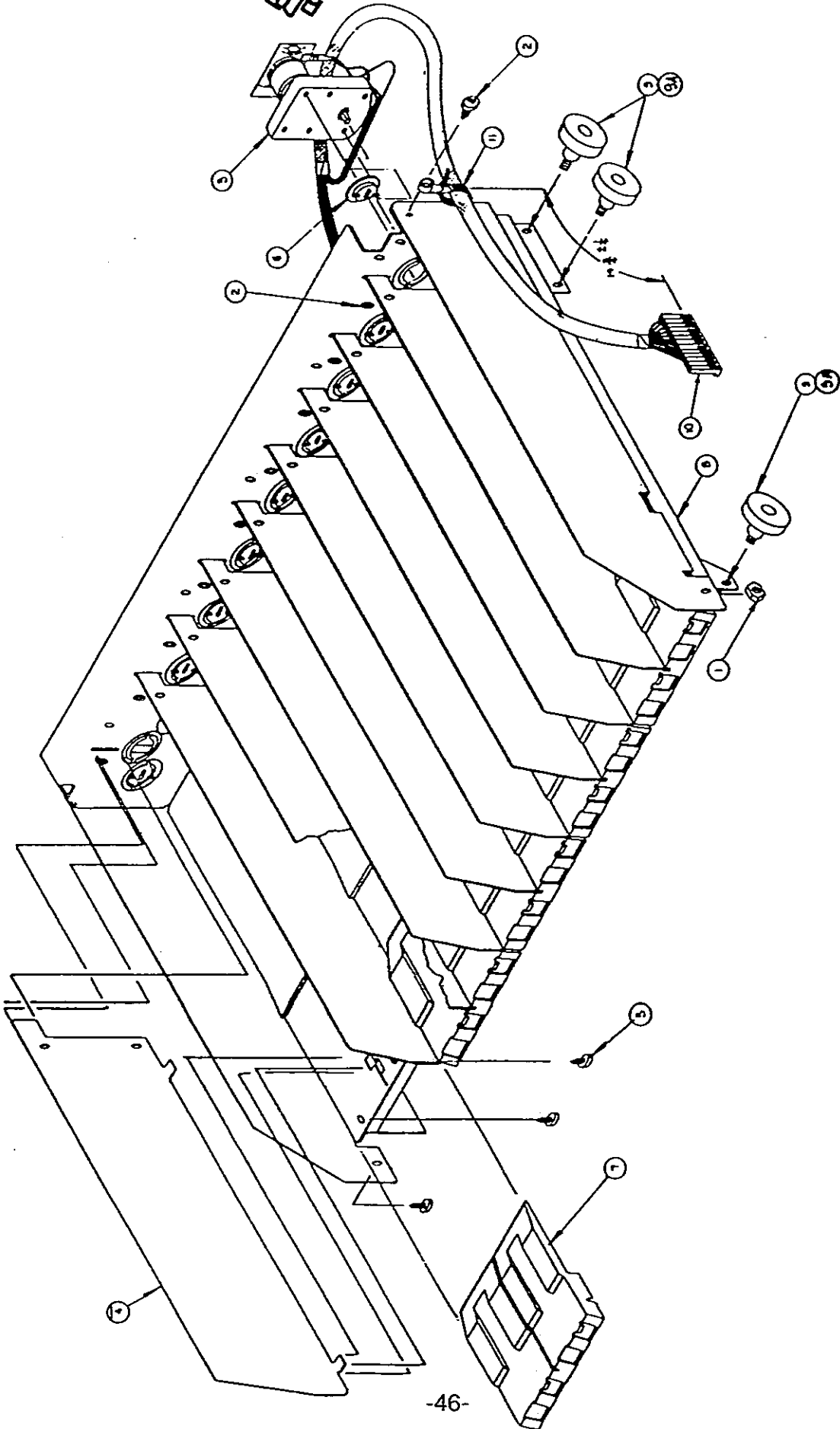

**CANDY TRAY ASSEMBLY**



**PARTS LIST**

**CANDY TRAY ASSEMBLY  
FULL SIZE MACHINE  
4000, 5000 AND 6000 SERIES**

ITEM	DESCRIPTION	PART NO.	QTY
1	NUT - HEX 1/4 - 20 CENTERLOC	18821	6
2	SCREW #8 - 18 X 1/2	2614-BLK	21
3	MOTOR - DC	18365-3CC	10
4	TRAY DIVIDER	17843-BLK	9
5	SCREW #8 PLASTILOC	19321	12
6	PLASTIC HUB COUPLING	17537	10
7	TRAY FRONT - CANDY	18925	5
8	SLIDING TRAY W.A.	19264-FBK	1
9	TRAY WHEEL	19729	6
9A	WHEEL AXLE	19728	6
10	WIRE HARNESS	19647	1
11	HARNESS TIE	80569	1

**CANDY TRAY ASSEMBLY  
MID-SIZE 4000M, 5000M AND 6000M**

ITEM	DESCRIPTION	PART NO.	QTY
1	NUT - HEX 1/4 - 20 CENTER LOC	18821	6
2	SCREW #8 - 18 X 1/2	2614-BLK	17
3	MOTOR - DC	18365-3CC	8
4	TRAY DIVIDER	17843-BLK	7
5	SCREW #8 PLASTILOC	19321	8
6	PLASTIC HUB COUPLING	17537	8
7	TRAY FRONT - CANDY	18925	4
8	SLIDING TRAY W.A.	19264-MBK	1
9	TRAY WHEEL	19729	6
9A	WHEEL AXLE	19728	6
10	WIRE HARNESS	19647	1
11	HARNESS TIE	80569	1

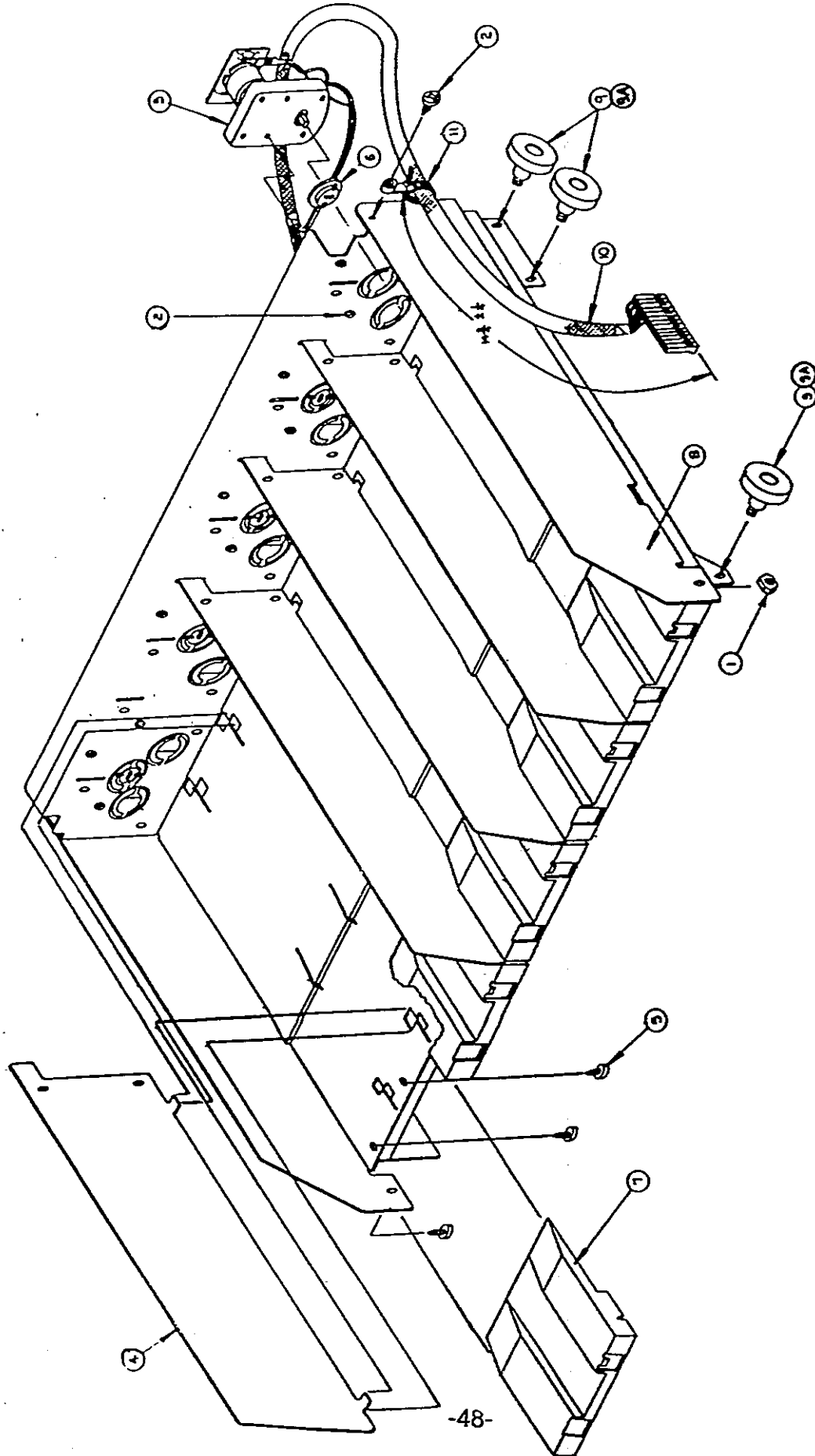

**PASTRY TRAY ASSEMBLY**





**PART LIST**

**PASTRY TRAY ASSEMBLY  
FULL SIZE 4000, 5000 AND 6000 SERIES**

ITEM	DESCRIPTION	PART NO.	QTY
1	NUT 1/4 - 20	18821	6
2	SCREW #8 - 18	2614-BLK	11
3	MOTOR - DC	18365-3CC	5
4	TRAY DIVIDER	17843-BLK	4
5	SCREW #8 - 18 X 3/8	19321	12
6	PLASTIC HUB COUPLING	17537	5
7	PASTRY TRAY FRONT	18926	5
8	SLIDING TRAY W.A.	19264-FBK	1
9	TRAY WHEEL	19729	6
9A	WHEEL AXLE	19728	6
10	WIRE HARNESS	19646	1
11	HARNESS TIE	80569	1

**PASTRY TRAY ASSEMBLY  
MID-SIZE 4000M, 5000M AND 6000M SERIES**

ITEM	DESCRIPTION	PART NO.	QTY
1	NUT 1/4 - 20 CENTER LOCK	18821	1
2	SCREW #8 - 18 X 1/2	2614-BLK	11
3	MOTOR DC	18365-3CC	4
4	TRAY DIVIDER	17843-BLK	3
5	SCREW # - 18 X 3/8	19321	8
6	PLASTIC HUB COUPLING	17537	4
7	PASTRY TRAY FRONT	18926	4
8	SLIDING TRAY W.A.	19264-MBK	1
9	TRAY WHEEL	19729	6
9A	WHEEL AXLE	19728	6
10	WIRE HARNESS	19724	1
11	HARNESS TIE	80569	1



## PARTS LIST CHAIN SEGMENT

ITEM	DESCRIPTION	PART NO.	QTY
-	COMPLETE ASSEMBLY	10416	-
1	COMPRESSION SPRING	1720	1
2	CYLINDRICAL WEDGE (2 REQ)	1754	2
3	CHAIN HOUSING SEGMENT	1723	1
4	SLIDE	1717	1
5	CYLINDER LIFTER	1719	1

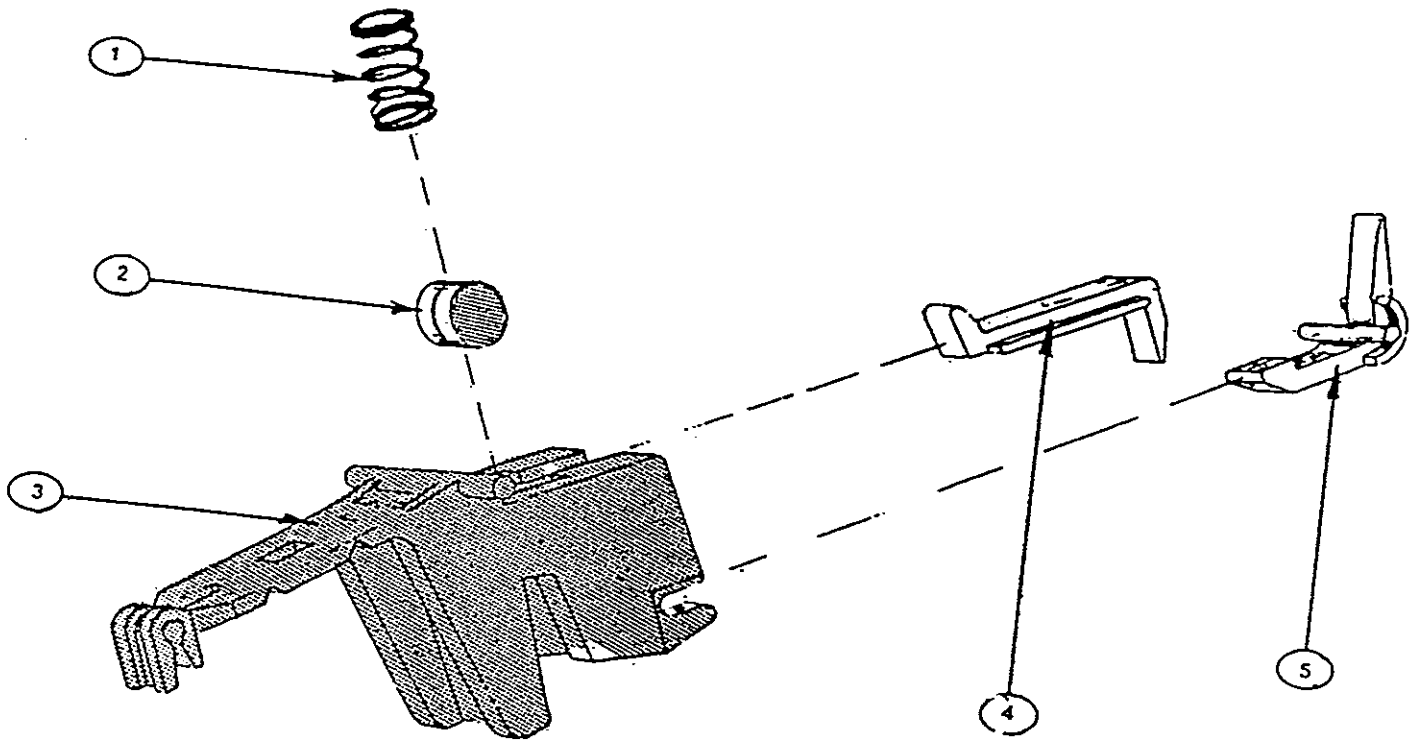

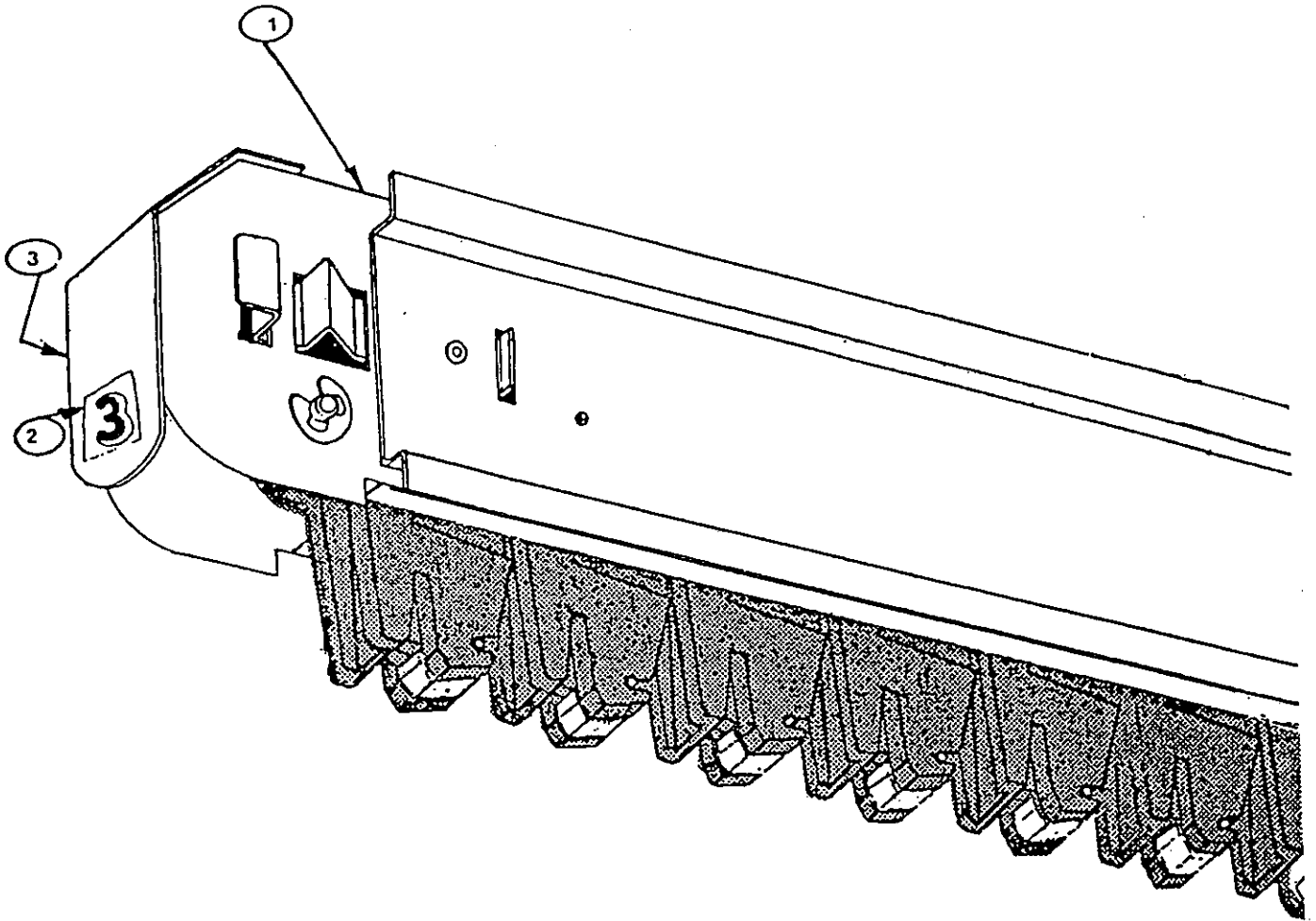

**PARTS LIST  
RACK MODULE END ASSEMBLY**

ITEM	DESCRIPTION	PART NO.	QTY
1	COMPLETE ASSEMBLY MODULE	10484-BK	-
2	DECAL SELECTION NUMBERS	18068	-
3	TAB AND STRIPPER ASSEMBLY	13597-BLK	1

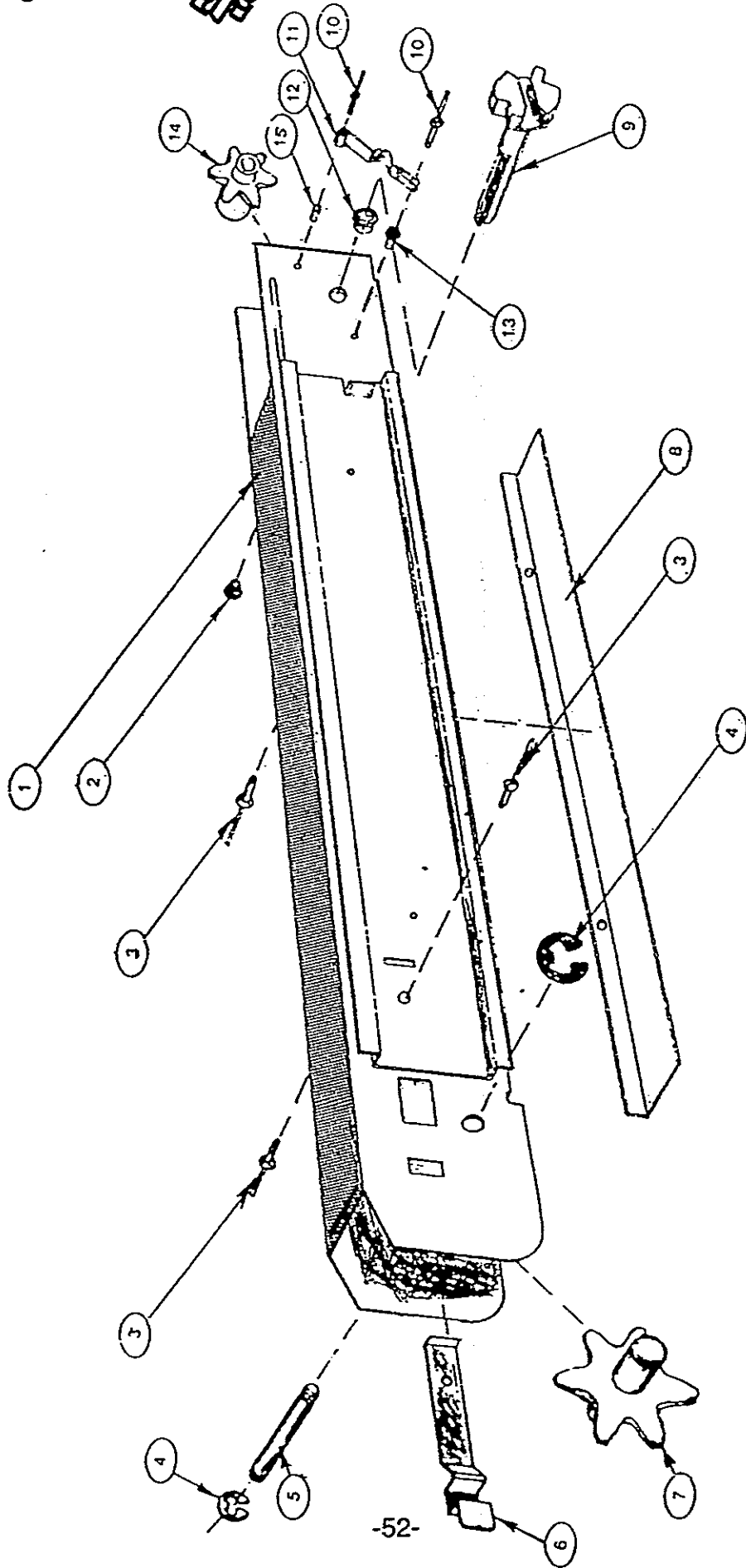

RACK MODULE ASSEMBLY



**PART LIST  
RACK MODULE**

ITEM	DESCRIPTION	PART NO.	QTY
-	COMPLETE ASSEMBLY	10484-BK	-
1	SLIDE & MODULE ASSEMBLY	10495-BLK	1
2	BUSHING	730	1
3	POP RIVET	729	4
4	E RING	2559	1
5	FRONT SPROCKET SHAFT	2558	1
6	SPRING LOCK	1744	1
7	FRONT SPROCKET	2565	1
8	CHAIN GUIDE	1774	1
9	REAR SPROCKET SHAFT	1741	1
10	POP RIVET	1642	2
11	DETENT SPRING REAR SPROCKET	1743	1
12	BEARING BUSHING	1178	1
13	DETENT SPRING T SPACER	1745	1
14	REAR SPROCKET	2563	1
15	DETENT SPRING PLAIN SPACER	1869	1
16	COMPLETE WEDGE CHAIN ASSY. 28 LINK	10487	1

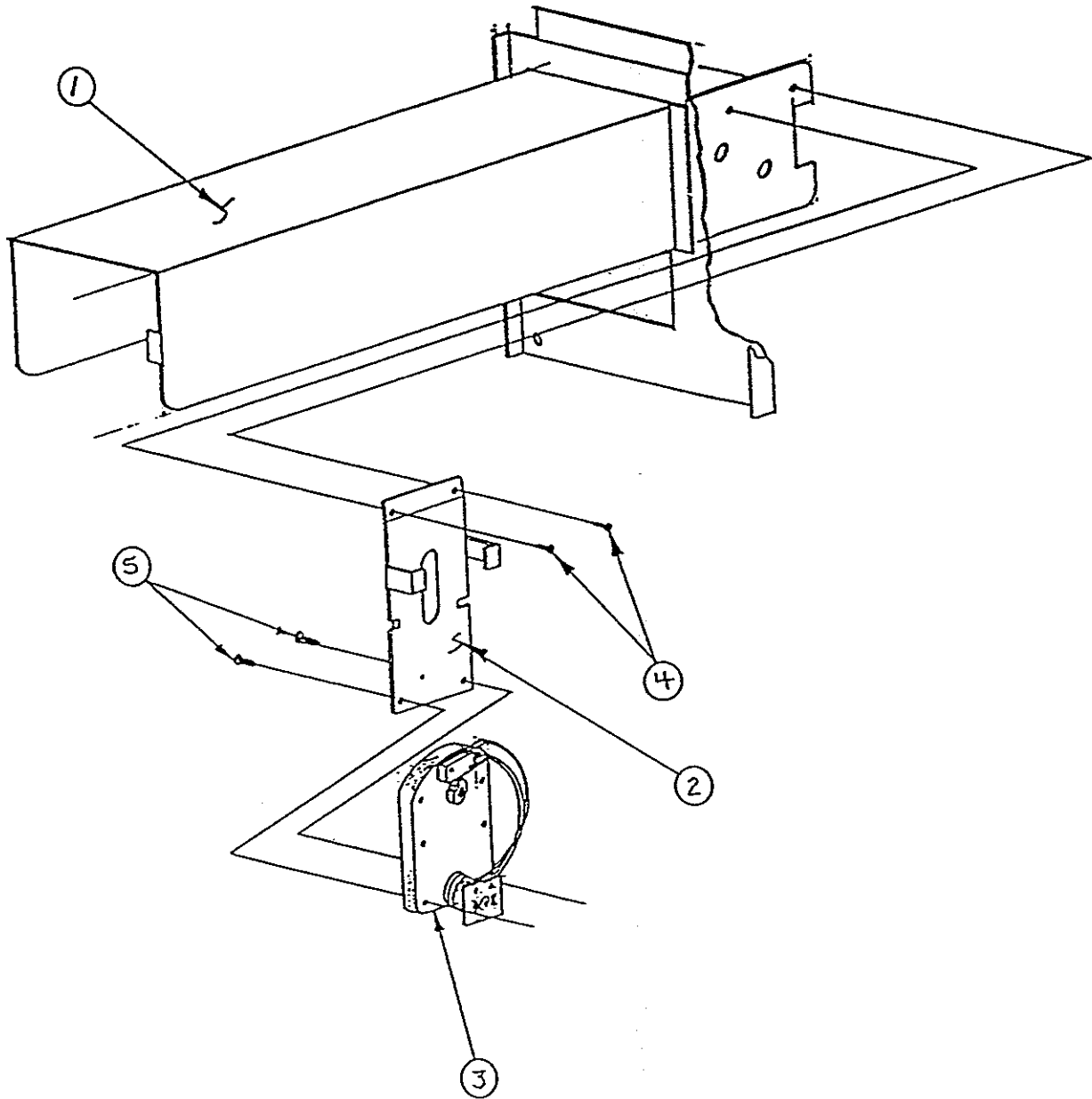

**PARTS LIST  
MODULE ARM MOTOR MOUNTING**

ITEM	DESCRIPTION	PART NO.	QTY
1	MODULE ARM	10483-BLK	-
2	MOUNTING PLATE	17658-BLK	1
3	MOTOR ^SSEMBLY COMPLETE	18365-1CC	1
4	SCREW #8 - 32 X 1/4	1868	4
5	SCREW #8 - 18 X 3/8	1298	4



**PARTS LIST  
WIRING DIAGRAM  
SLIDING DRAWER ASSEMBLY**

ITEM	DESCRIPTION	PART NO.	QTY
34	INTERLOCK SWITCH	19746	1
38	DISPLAY HARNESS	19735	1
39	CLAMP 3/8"	8538-01	1
40	POWER HARNESS	19736	1
41	INTERCONNECT HARNESS	19642	1
42	WIRE CLAMP 5/8"	8538-02	1
43	POWER HARNESS MS-1600	19816	1
44	NOT USED	-	-
45	DATA HARNESS MS-1600	19740	1
47	CONNECTOR MS-1600-ENABLE	19946	1

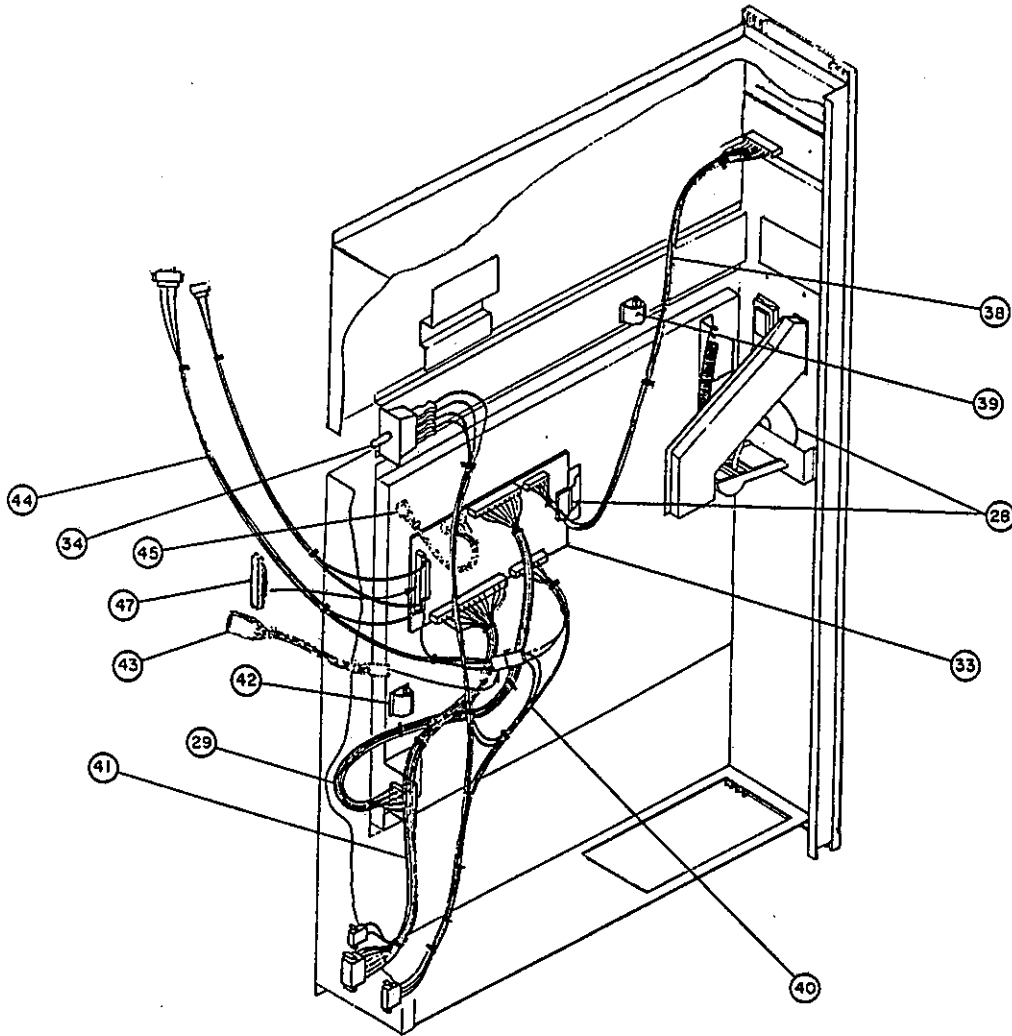

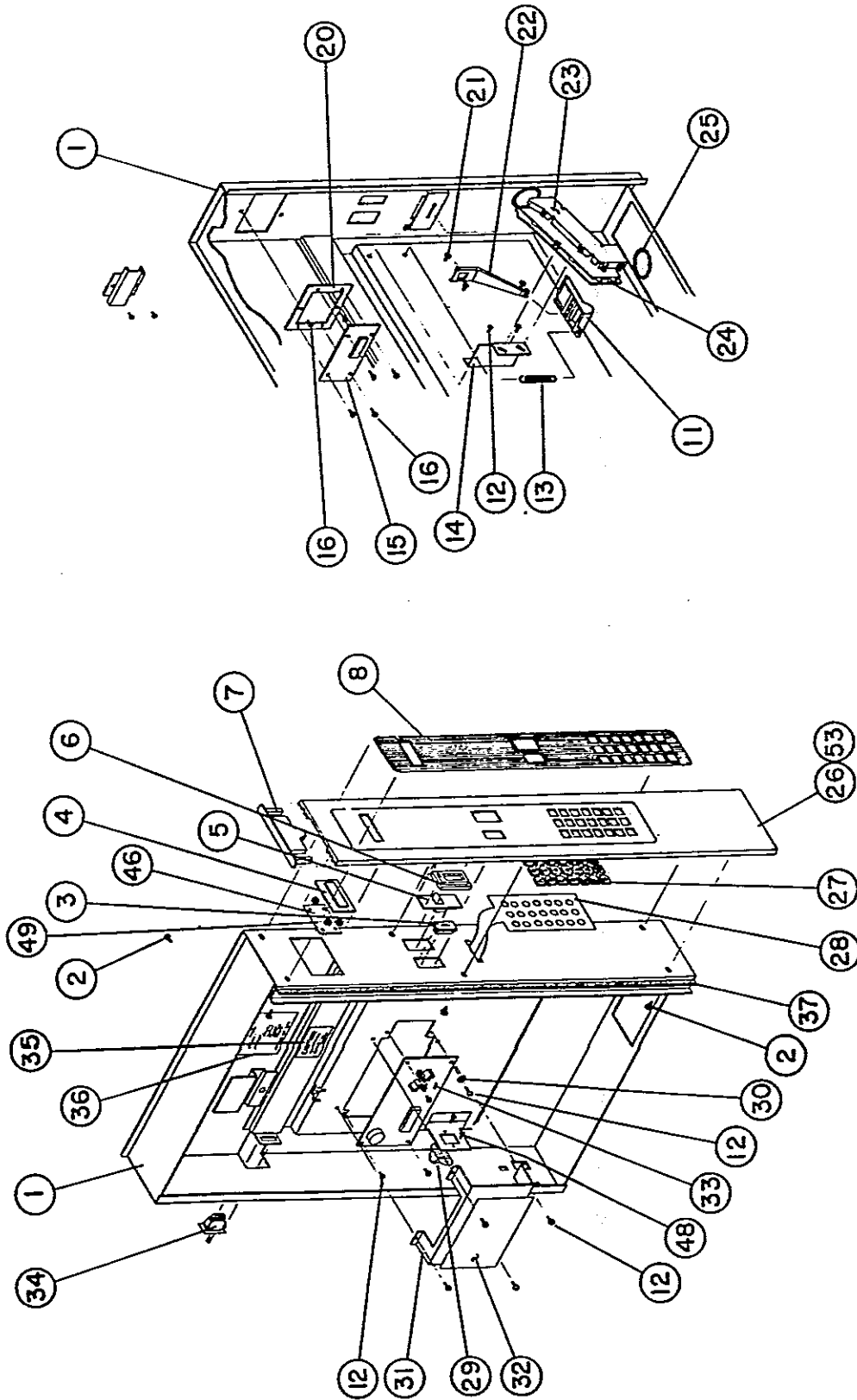

**SLIDING DRAWER ASSEMBLY**





**PARTS LIST  
SLIDING DRAWER ASSEMBLY**

ITEM	DESCRIPTION	PART NO. BROWN MACH.	PART NO. WHITE MACH.	PART NO. DARK GREY MACH.	QTY
1	DRAWER	19640-BLK	19640-BLK	19640-BLK	1
2	SCREW #10-24X5/16	13140	13140	13140	6
3	COIN INLET	17948	17948	17948	1
4	LENS	19588	19588	19588	1
5	SCAVENGE SLIDE	17904	17904	17904	1
6	SCAVENGE SLIDE HOLDER	17901	17901	17901	1
7	MID-CAP	17916-BLK	17916-BLK	17916-BLK	1
8	ESCUTCHEON DECAL	19656-UK	19656-UKB	19656-UKG	1
9	NOT USED	-	-	-	-
9A	NOT USED	-	-	-	-
10	NOT USED	-	-	-	-
11	SCAVENGER PLATE	17798-BLK	17798-BLK	17798-BLK	1
12	SCREW #8-18X3/8	1298-BLK	1298-BLK	1298-BLK	1
13	EXTENSION SPRING	611	611	611	1
14	CHUTE RETAINER BRACKET	18063-BLK	18063-BLK	18063-BLK	1
15	DIGITAL DISPLAY	19574-DIS	19574-DIS	19574-DIS	1
16	SCREW #8-18X1/4	1868-BLK	1868-BLK	1868-BLK	2
17	NOT USED	-	-	-	-
18	NOT USED	-	-	-	-
20	MOUNTING DISPLAY BKT.	19644-BLK	19644-BLK	19644-BLK	1
21	SCREW #8-32X3/8	11894	11894	11894	1
22	SCAVENGE LINK	17800	17800	17800	1
23	COIN CHUTE COVER	17803	17803	17803	1
24	REAR COIN CHUTE	17804	17804	17804	1
25	"O" RING	19610	19610	19610	2
26	ESCUTCHEON PLATE	19575-BLK	19575-BLK	19575-BLK	1
27	BUTTON (NEW STYLE)	19909-SET	19909-SET	19909-SET	1
28	KEYPAD	19576	19576	19576	1
29	NOT USED	-	-	-	-
30	#8 INTERNAL WASHER	266	266	266	1
31	CONTROLLER COVER	19773-BLK	19773-BLK	19773-BLK	1
32	COVER DECAL, CONTROLLER	19793	19793	19793	1
33	CONTROL BOARD	20759-CNT	20759-CNT	20759-CNT	1
34	INTERLOCK SWITCH	19746	19746	19746	1
35	CAUTION - DECAL	19819	19819	19819	1
36	INSTRUCTION DECAL	19766	19766	19766	1
37	NEOPRENE STRIP 3/8"	810-00	810-00	810-00	853.44MM
46	DISPLAY FILTER	19860	19860	19860	1
48	SCREW #6-20 X 3/16	18370-BLK	18370-BLK	18370-BLK	2
49	#8-32 NUT	1958	1958	1958	4
50	NOT USED	-	-	-	-

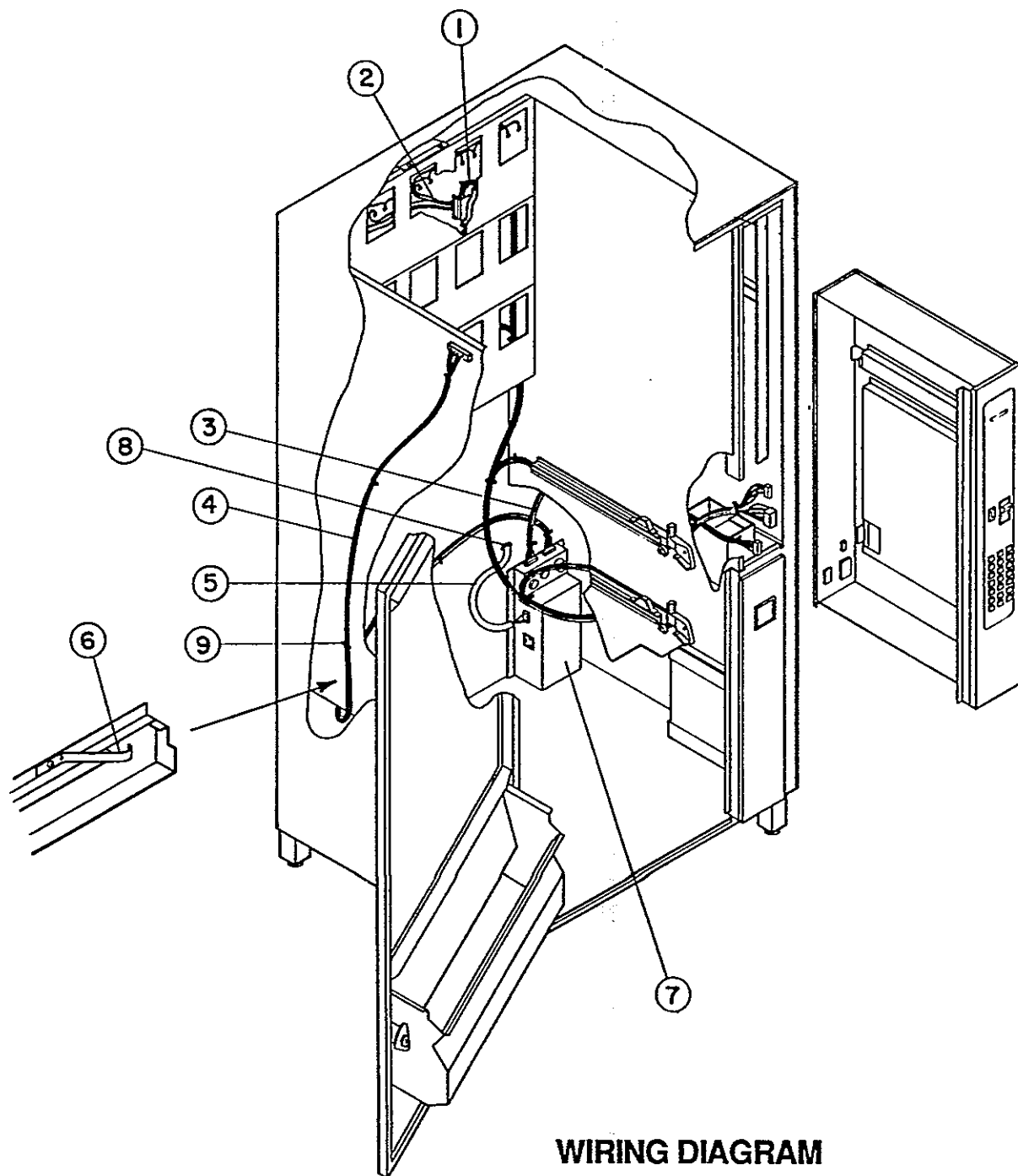

**WIRING DIAGRAM**



**PARTS LIST  
ELECTRICAL WIRING DIAGRAM**

ITEM	DESCRIPTION	PART NO.	QTY
1	MOTOR HARNESS	19996 #	1
	FOUR ROW	19643 #	1
	FIVE ROW	19995 #	1
	SIX ROW		
2	WEDGE MODULE HARNESS	17727	3
3	POWER JUMPER HARNESS	18391	1
4	LAMP HARNESS SUBASSEMBLY	17912-UK	1
5	POWER CORD	17946-UK	1
6	ELECTRICAL GROUND CLIP	19745	5
7	HI-VOLTAGE POWER BOX	19992-240 *	1
8	STRAIN RELIEF BUSHING	2438	1
9	HARNESS TIES	80569	5

\* Full size machine part number listed. The mid-size machine part number is 19993-240.

# Harness used in all helix machine also.  
 Four tray harness same as four row harness.  
 Five tray harness same as five row harness.  
 Six tray harness same as six row harness.



**MID-SIZE POWER BOX ASSEMBLY**

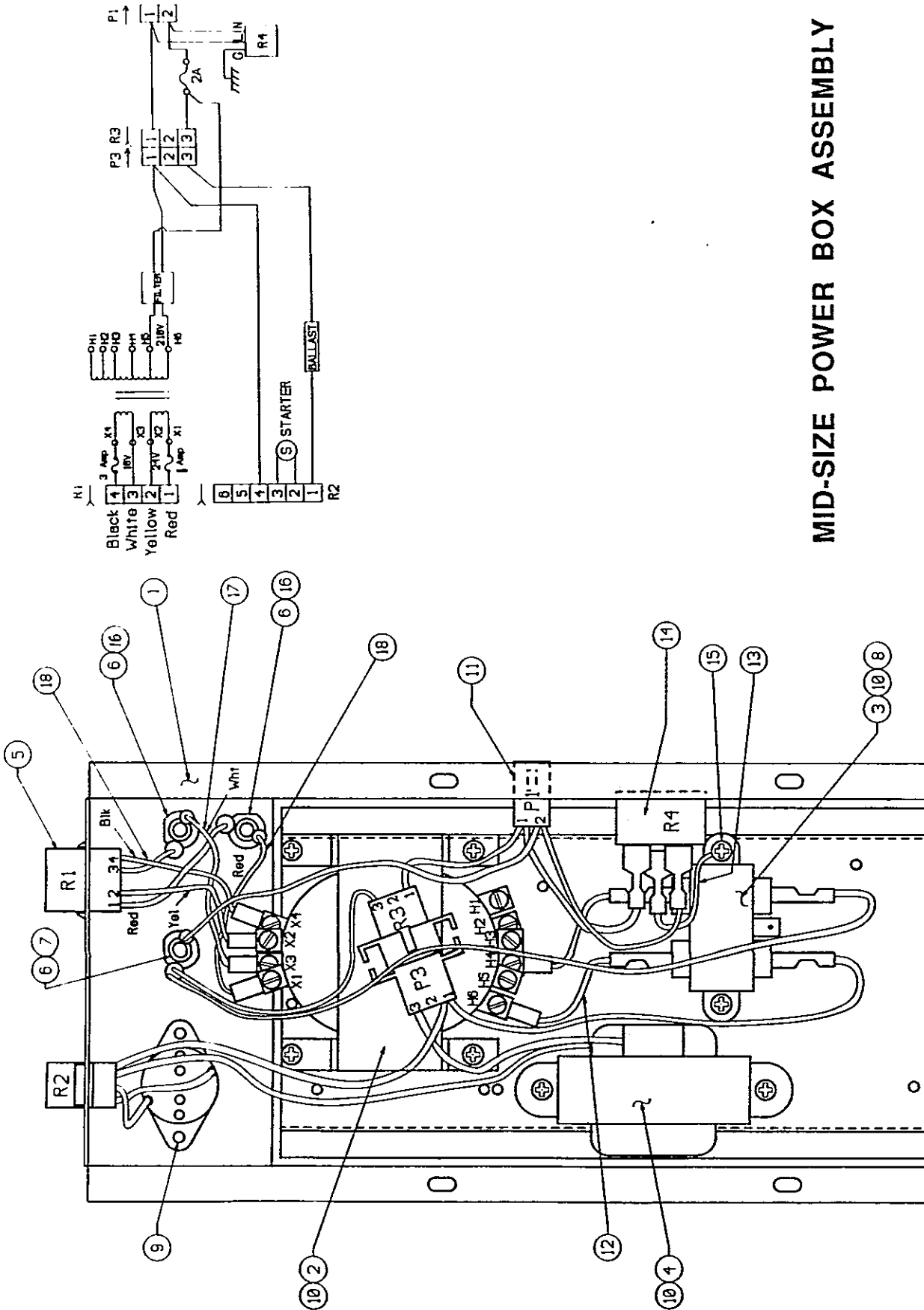

19992-210	210 TAP
19992-220	220 TAP
19992-230	230 TAP
19992-240	240 TAP
19992-250	250 TAP
P/N	SET TRANSFORMER PRIMARY TAP TO



**PARTS LIST  
MID-SIZE POWER BOX ASSEMBLY**

ITEM	DESCRIPTION	PART NO.	QTY
-	POWER BOX ASSEMBLY COMPLETE	19993-240	1
1	POWER BOX	19989-BLK	1
2	TRANSFORMER	17753	1
3	RFI FILTER	20758	1
4	BALLAST ASSY.	17915-240	1
5	JUMPER HARNESS	19990	1
6	FUSE HOLDER	18434	3
7	FUSE 2 AMP	222	1
8	#8 INTERNAL WASHER	266	1
9	SCREW 6-32 X 3/8	302	2
10	SCREW	1298-BLK	6
11	FUSE HARNESS	19702	1
12	TRANSFORMER JUMPER EXP.	17942	2
13	GROUND HARNESS	19703	1
14	POWER BOX OUTLET EXP.	19663	1
15	SCREW #8	1715	1
16	3 AMP FUSE	20235	2
17	RED JUMPER	19991-RED	1
18	WHITE JUMPER	19991-WHT	1

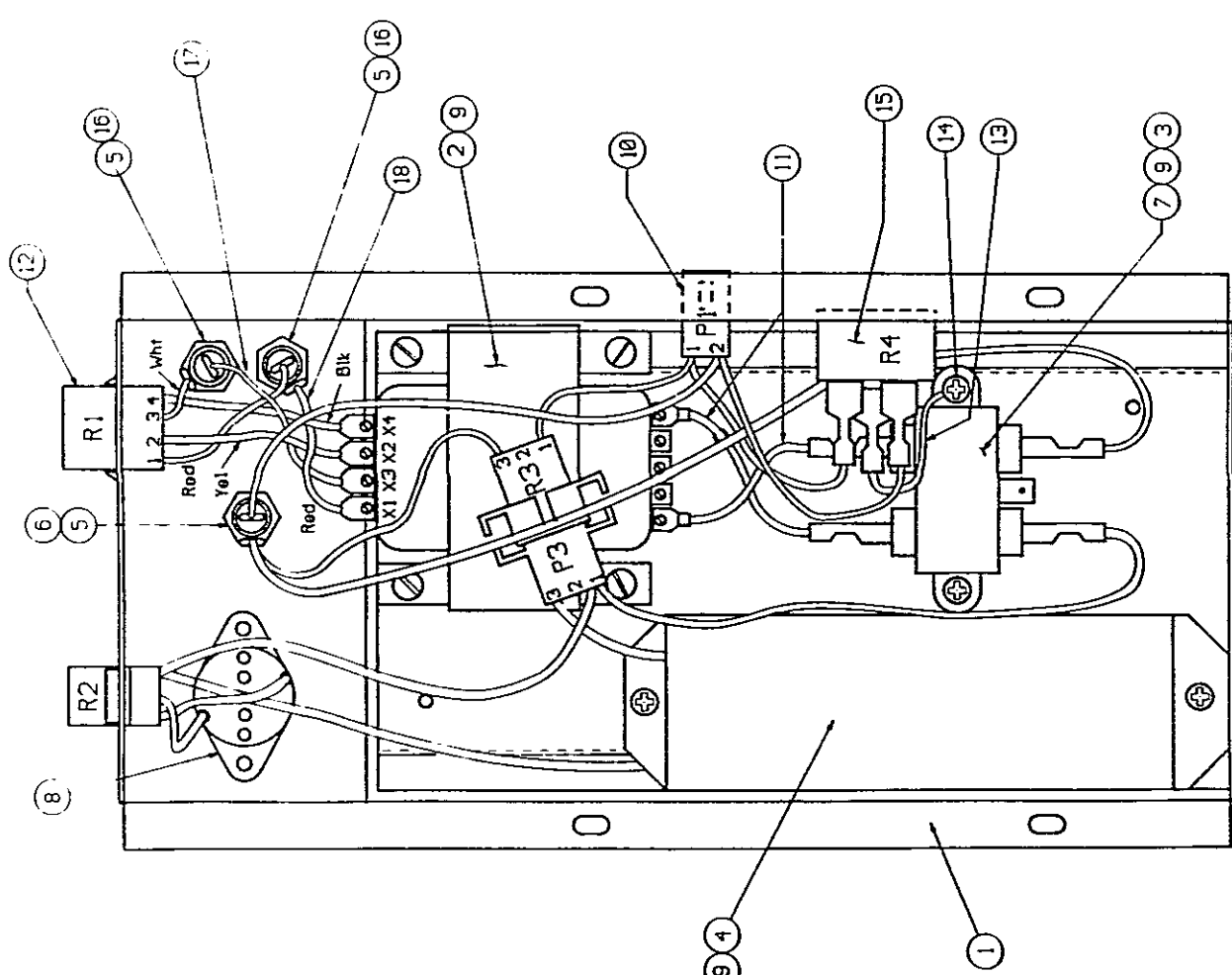
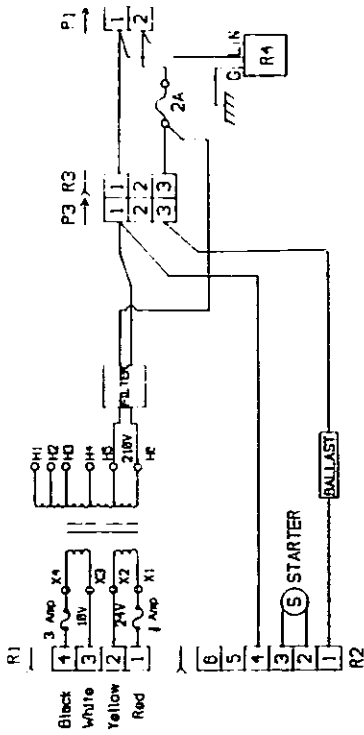

**FULL SIZE POWER BOX ASSEMBLY**

19993-210	210 TAP
19993-220	220 TAP
19993-230	230 TAP
19993-240	240 TAP
19993-250	250 TAP
P/N	SET TRANSFORMER PRIMARY TAP TO.



**PARTS LIST  
FULL SIZE POWER BOX ASSEMBLY**

ITEM	DESCRIPTION	PART NO.	QTY
-	POWER BOX COMPLETE ASSEMBLY	19992-240	1
1	POWER BOX W.A.	19989-BLK	1
2	TRANSFORMER 24V	17753	1
3	RFI FILTER	20758	1
4	BALLAST ASSY. 240V	18870-240	1
5	FUSE HOLDER	18434	3
6	2 AMP HOLDER	222	1
7	INTERNAL TOOTH WASHER #8	266	1
8	SCREW 6-32 X 3/8	302	2
9	SCREW	1298-BLK	6
10	FUSE HARNESS	19702	1
11	UK-TRANSFORMER 220V JUMPER	17942	1
12	JUMPER 24/10V - UK	19990	1
13	GROUND HARNESS	19703	1
14	#8 PAN HEAD SCREW	1715	1
15	POWER BOX OUTLET/EXPORT	19663	1
16	3 AMP. FUSE	20235	2
17	WHITE JUMPER	19991-WHT	1
18	RED JUMPER	19991-RED	1

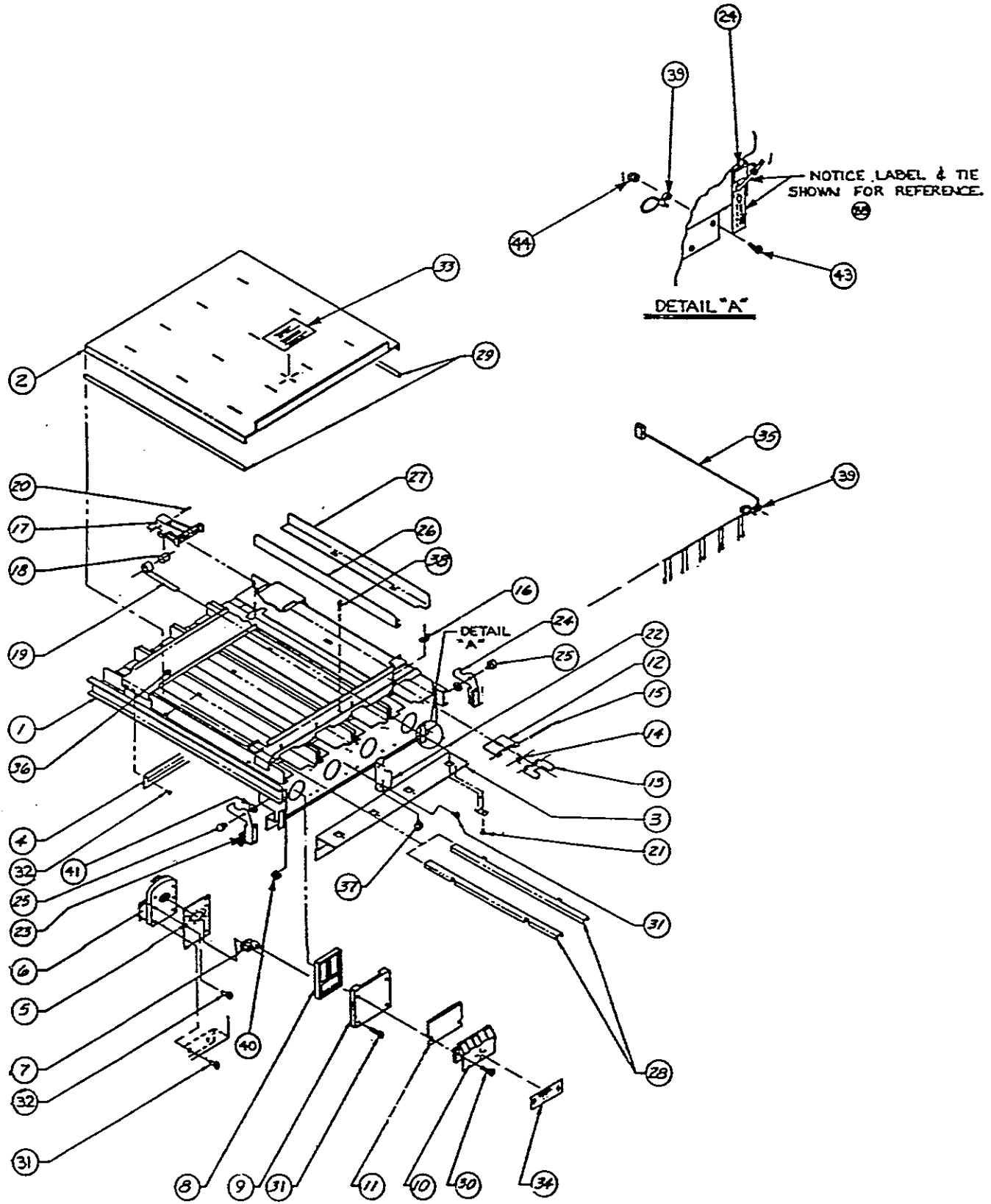

**GUM AND MINT ASSEMBLY**





**PARTS LISTS  
GUM AND MINT ASSEMBLY**

ITEM	DESCRIPTION	PART NO. THREE SELECTION	PART NO. FOUR SELECTION	QTY 3 SEL	QTY 4 SEL
1	RACK ASSEMBLY	19159-BLK	19157-BLK	1	1
2	PRODUCT COVER	19143-BLK	19141-BLK	1	1
3	PUSHER SPRING RET.	19154-BLK	19152-BLK	1	1
4	PUSHER STOP CHANNEL	19148-BLK	19147-BLK	1	1
5	MOTOR PLATE	19063-BLK	19063-BLK	1	1
6	D.C. MOTOR	18365-3CC	18365-3CC	3	4
7	MOTOR CAM	19064	19064	3	4
8	PRODUCT RELEASE ACT.	19072	19072	3	4
9	PRODUCT ACTUATOR BLK.	19073	19073	3	4
10	GUM AND MINT SEL. HLD.	19071	19071	3	4
11	GUM AND MINT WINDOW	19070	19070	3	4
12	GATE MOUNTING PLATE	19067-BLK	19067-BLK	3	4
13	GUM AND MINT GATE	19065	19065	3	4
14	GATE SPRING	19066	19066	3	4
15	GATE PIN	19068	19068	3	4
16	WING NUT	19170	19170	3	4
17	GUM AND MINT PUSHER	19075	19075	3	4
18	SPRING SPINDLE	19128	19128	3	4
19	NEGATOR	19165	19165	3	4
20	ROLL PIN	19171	19171	3	4
21	SELF TAPPING SCREW	18033	18033	3	4
22	RACK PULL	19137-BLK	19137-BLK	1	2
23	LATCH	19139-LHB	19139-LHB	1	1
24	LATCH	19139-RHB	19139-RHB	1	1
25	LATCH PIVOT SCREW	19138	19138	2	2
26	NOT USED	-	-	-	-
27	NOT USED	-	-	-	-
28	PRODUCT HEIGHT ADAPT.	19166-BLK	19166-BLK	2	4
29	NYLON GUIDE	19155	19155	2	2
30	SCREW SELF TAPPING	19640-BLK	19640-BLK	6	8
31	SCREW SELF TAPPING	1299-BLK	1299-BLK	12	16
32	SCREW SELF TAPPING	1298-BLK	1298-BLK	18	24
33	CAUTION DECAL	19174	19174	1	1
34	SHELF LATCH DECAL	19175	19175	1	1
35	GUM AND MINT HARNESS	19169	19169	1	1
36	SNAP BUSHING	19176	19176	2	2
37	BUMPER	326	326	1	2
38	SCREW SELF TAPPING	19173	19173	1	1
39	HARNESS TIE CLAMP	80569	80569	1	1
40	LOCK NUT	19458	19458	2	2
41	FLAT WASHER	4280	4280	2	2
42	NOT USED	-	-	-	-
43	MACHINE SCREW	1465-BLK	1465-BLK	1	1
44	NUT	1958	1958	1	1

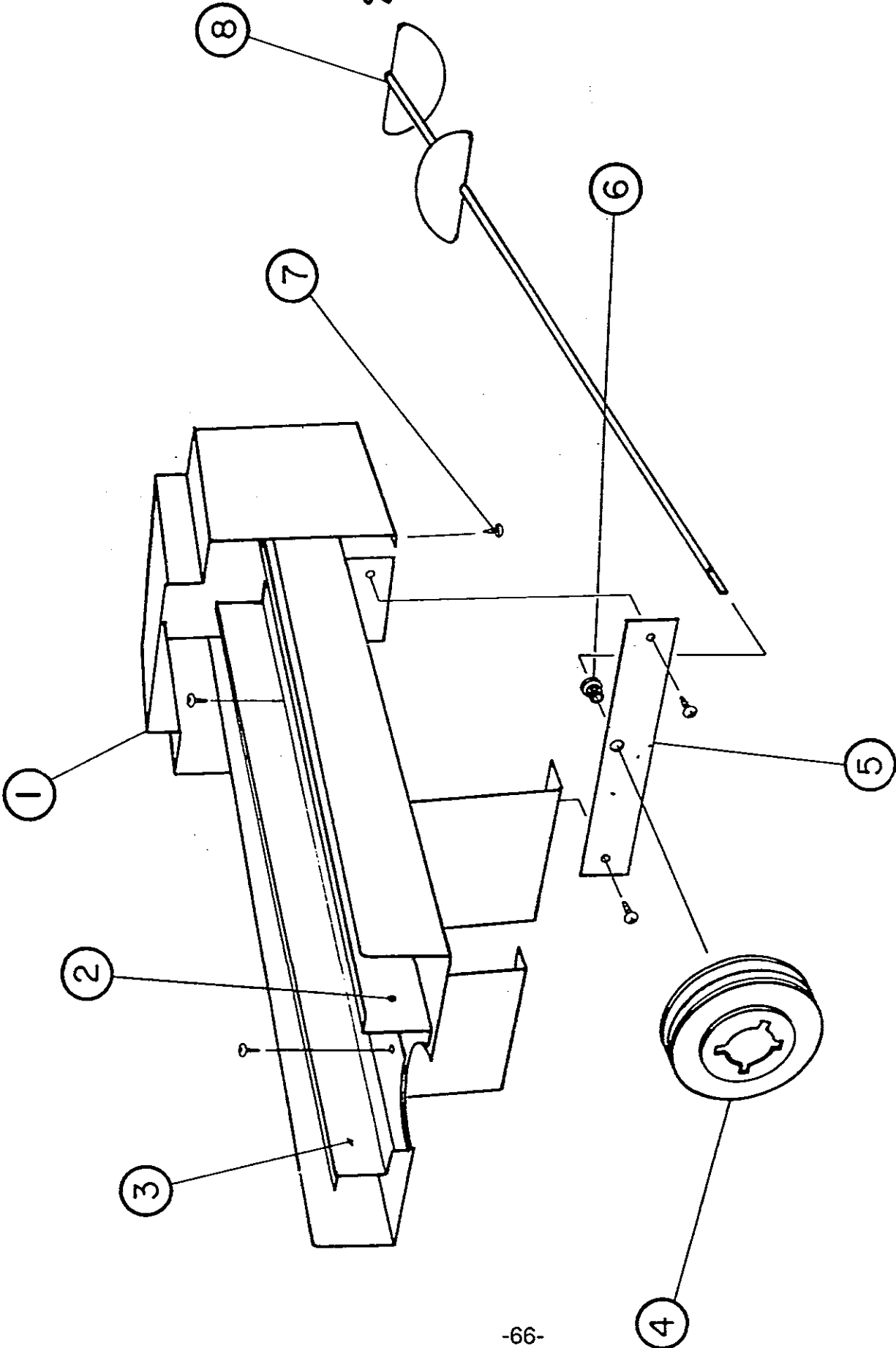

CAN DISPENSER ASSEMBLY



**PARTS LIST  
CAN DISPENSER**

ITEM	DESCRIPTION	PART NO.	QTY
-	CAN DISPENSER UNIT COMPLETE	19658	1
1	CAN VENDOR MAIN ASSY.	19623	1
2	LUNCH BUCKET CHANNEL	19616-BLK	1
3	LEFT SIDE LUNCH BUCKET CHANNEL	19743-BLK	1
4	ADAPTER HUB	19660	1
5	AUGER MOUNTING PLATE	19654	1
6	AUGER BUSHING	18755	1
7	MOUNTING SCREW	19321	1
8	AUGER	19655	1

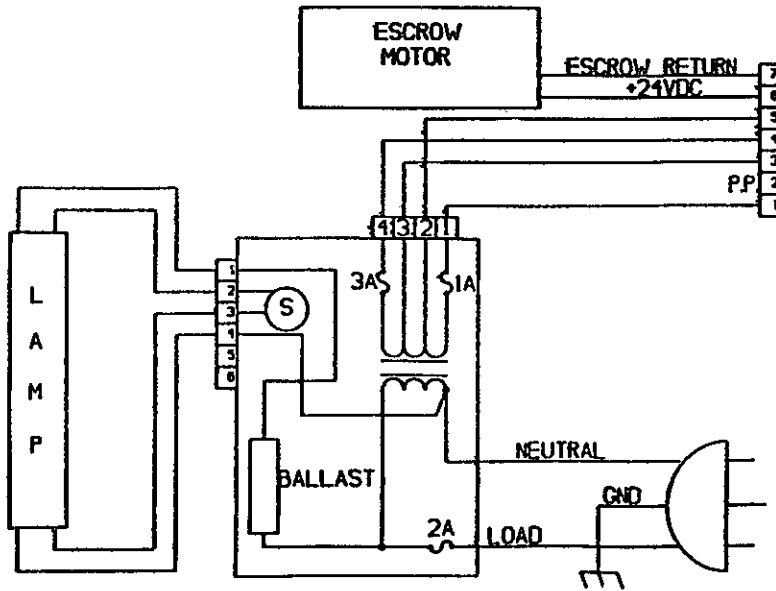
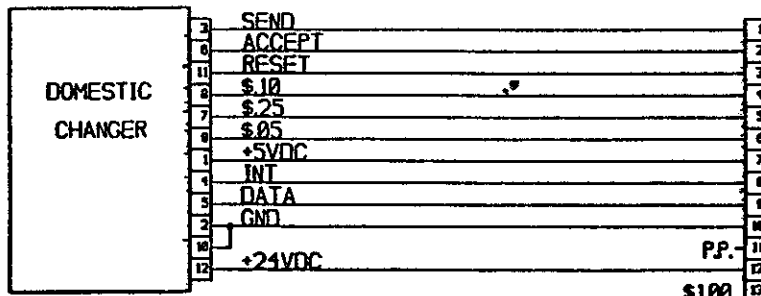
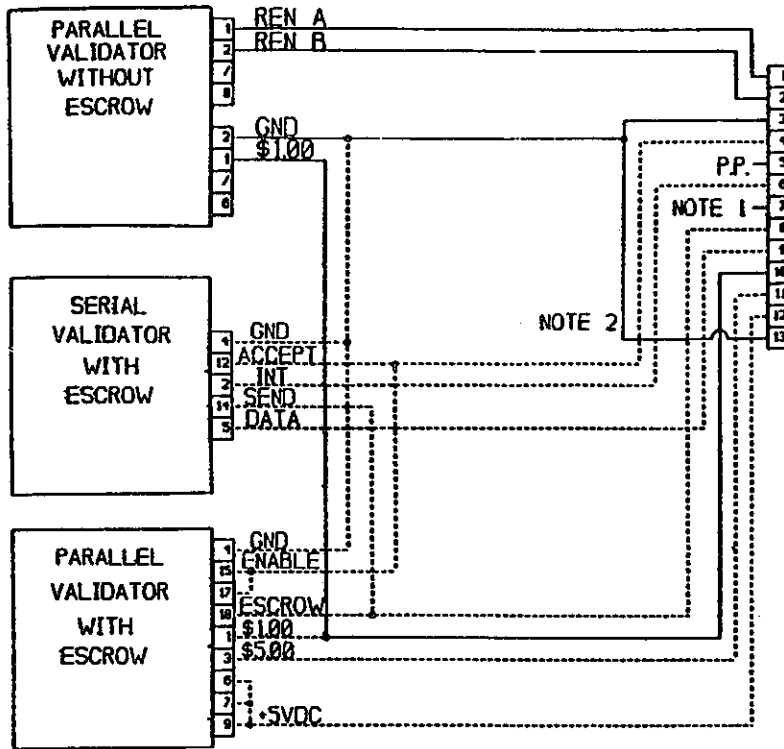

- CLOCK DATA
- P.P. RESET
- VDD
- VSS
- VGG
- FIL -A
- FIL -B
- GND
- P.P.
- RX(+)
- RX(-)
- TX(-)
- TX(+)
- P.P. GRD
- ROW B
- ROW A
- NC
- ROW E
- ROW D
- ROW C
- P.P. COLUMN 5
- COLUMN 4
- COLUMN 6
- COLUMN 2
- COLUMN 1
- COLUMN 7
- COLUMN 3
- COLUMN 9
- COLUMN 8
- COLUMN 0
- ROW F
- ROW G

REMOTE  
DISPLAY

EXPORT  
CHANGER

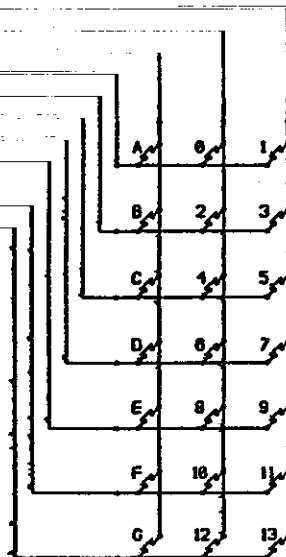

PIN 9 IS KEY POSITION

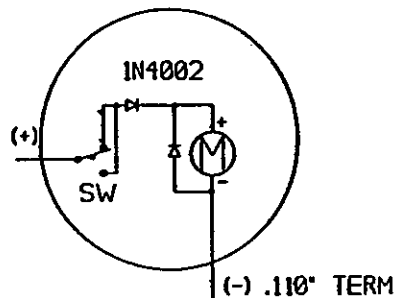

TYPICAL MOTOR

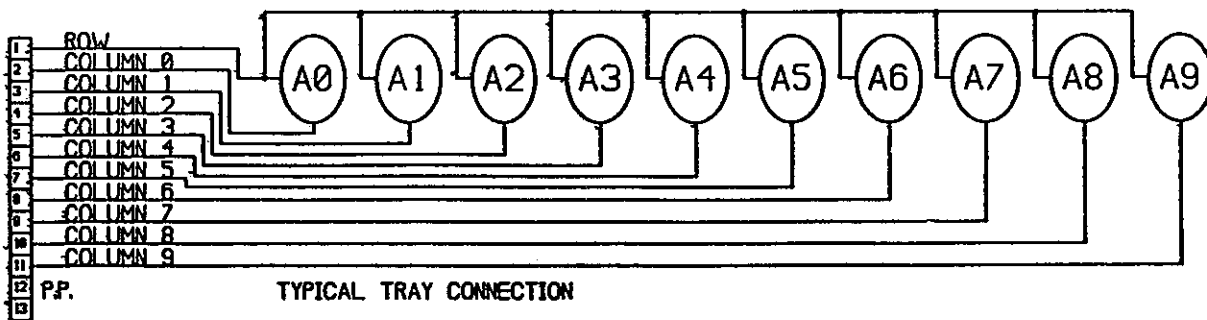

TYPICAL TRAY CONNECTION

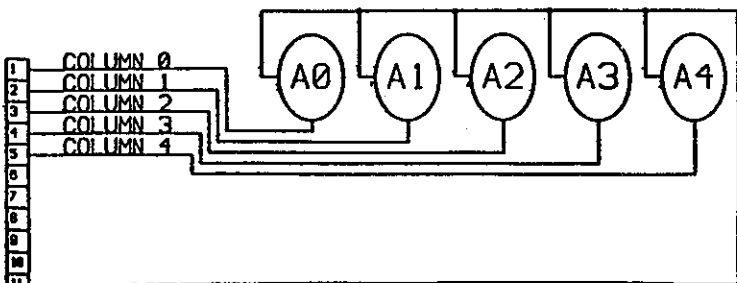

TYPICAL GUM & MINT CONNECTION



**Polyvend** LTD.

Station Lane  
Whitney  
Oxon OX8 6BU  
England  
Phone 0993 774 601/9  
Telex 837534 Polven  
Fax 0993 771830